



**PHOENIX**

"RISE SYSTEM"

**PHOENIX PANEL SYSTEMS SCOPE OF WORK: SUPPLY ONLY**

A. PANEL SYSTEM:	PHOENIX "RISE" PANEL SYSTEM
B. PANEL FACE MATERIAL:	4mm CORE
C. FASTENERS:	BY OTHERS
D. MOISTURE BARRIER:	BY OTHERS
E. PANEL CAVITY INSULATION:	BY OTHERS
F. SUBFRAMING:	BY OTHERS
G. FLASHING:	BY OTHERS

• ALL PANEL, SPLINE, CLOSURE, SILL, AND FLASHING SIZES TO BE MEASURED FROM SITE. SHOP DRAWINGS AND DIMENSIONS ARE FOR REFERENCE ONLY

• REFERENCE ARCHITECTURAL DRAWINGS TO CONFIRM ARCHITECTS INTENT FOR ALIGNMENT OF ALL PANELS AND JOINTS BEFORE COMMENCEMENT OF SITE MEASUREMENTS

• THE INFORMATION CONTAINED ON THESE DRAWINGS IS PROPRIETARY AND WILL NOT BE COPIED OR DISCLOSED TO OTHERS WITHOUT THE EXPRESS WRITTEN PERMISSION OF PHOENIX PANEL SYSTEMS © 2013

• DETAILS IN THIS MANUAL MAY CHANGE AS APPROVED BY CONSULTANTS

• EXTRUSION SHAPES SHOWN ARE GENERIC REPRESENTATIONS OF PHOENIX PANEL SYSTEMS

**1.0 MATERIAL**

**1.1 MATERIAL TYPE**

1.1.1 ACM MATERIAL CONSISTS OF A CORE THERMOPLASTIC MATERIAL BONDED TO FACE SHEETS FABRICATED OF ALUMINUM ALLOY 4mm THICK

**1.2 DIRECTIONALITY**

1.2.1 PAY CLOSE ATTENTION TO THE DIRECTION OF THE MATERIAL DURING INSTALLATION. MOST ACM MATERIAL IS DIRECTIONAL AND MUST BE INSTALLED IN ONE CONSISTENT DIRECTION. IN ORDER TO MAINTAIN COLOR AND FINISH CONSISTENCY ACROSS PANELS..

**1.3 VENTING AND WEEPAGE**

1.3.1 EACH PANEL SHALL HAVE AT LEAST ONE PRESSURE EQUALIZATION VENT. IT IS TO BE LOCATED AT BOTTOM OF PANEL AND ALONG SIDES IF REQUIRED. NO VENT SHALL BE LOCATED AT TOP EDGE OF PANEL.

1.3.2  $\frac{3}{16}$ "  $\phi$  WEEP HOLES SHALL BE DRILLED INTO BASE PERIMETER FRAME.

**2.0 HANDLING AND INSTALLATION**

**2.1 UNLOADING**

2.1.1 ACM PANELS ARE QUALITY FINISHED ARCHITECTURAL PRODUCTS AND MUST BE HANDLED WITH CARE TO PREVENT DAMAGE TO THE INDIVIDUAL COMPONENTS

2.1.2 UNLOADING MAY REQUIRE THE USE OF MECHANICAL LIFT OR HOIST EQUIPMENT DUE TO THE WEIGHT AND SIZE OF BUNDLES

**2.2 SITE STORAGE**

2.2.1 LOCATE THE MATERIAL AT CONVENIENT LOCATIONS AROUND THE PERIMETER OF THE BUILDING, TO MINIMIZE HANDLING DURING INSTALLATION

2.2.2 STORAGE SHOULD BE REASONABLY LEVEL. IF TERRAIN IS NOT LEVEL, USE WOOD BLOCKING TO MAKE BUNDLES LEVEL

**2.2.3 DO NOT STACK CRATES.**

2.2.4 OPEN BUNDLES SHOULD BE FIRMLY TIED AND COVER WITH POLYETHYLENE WHEN INSTALLATION IS STOPPED AT THE END OF THE DAY

2.2.5 PROTECT FACE SIDE OF PANELS FROM SUN BY BLACK POLYETHYLENE COVER UNTIL PANELS ARE READY FOR INSTALLATION

**2.3 PANEL HANDLING**

2.3.1 CARRY PANELS AND TRIMS ON EDGE IN A VERTICAL POSITION FOR STIFFNESS. (FIG. 1)

2.3.2 CARRYING PANELS IN A FLAT HORIZONTAL POSITION CAUSE DEFORMATION. AVOID CARRYING FLAT. (FIG. 2)

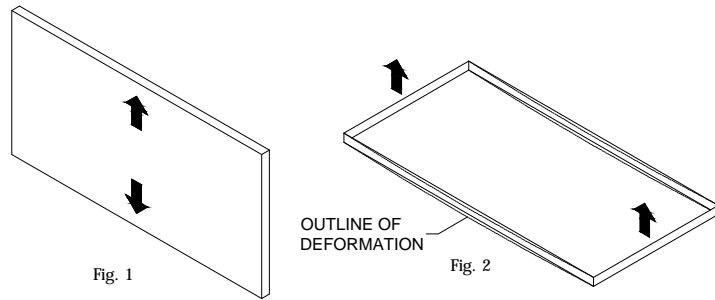

**2.6 EXTRUSIONS**

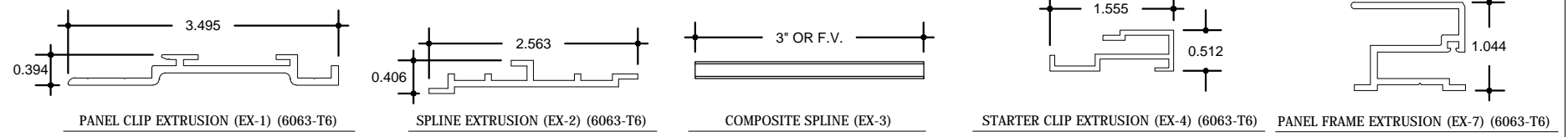

**2.4 INSTALLATIONS AND TOLERANCES**

2.4.1 PRIOR TO INSTALLATION, INSPECT STRUCTURE TO ENSURE ALL WALLS AND OPENINGS ARE WITHIN  $\frac{1}{8}$ " or 3mm OF LOCATION SHOWN ON ARCHITECTURAL DRAWINGS. INSTALLATION IS NOT TO PROCEED UNTIL THE BUILDING IS WITHIN THESE TOLERANCES.

2.4.2 ALL SUPPORTS UTILIZED FOR THE ACM PANEL SYSTEM TO BE STRUCTURALLY ADEQUATE AND APPROPRIATELY ATTACHED TO SUPPORT AND TRANSMIT LOADS APPLIED BY PANEL SYSTEM COMPONENTS.

2.4.3 ANCHOR PANELS SECURELY IN PLACE, IN ACCORDANCE WITH APPROVED SHOP DRAWINGS.

2.4.4 PLASTIC HORSESHOE SHIMS ( $\frac{1}{16}$ "/1.5mm,  $\frac{1}{8}$ "/3mm, AND  $\frac{1}{4}$ "/6mm THICKNESS) ARE RECOMMENDED TO MAKE ADJUSTMENTS AT TIME OF INSTALLATION

2.4.5 MAXIMUM DEVIATION FROM HORIZONTAL AND VERTICAL ALIGNMENT OF INSTALLED PANELS:  $\frac{1}{4}$ "/6.4mm IN 20'/6100mm NON-CUMULATIVE

2.4.6 ALL PANEL CLIPS MUST BE FASTENED INTO SUBGIRTS OR WALL STUDS OR CONCRETE BY OTHERS FOR HORIZONTAL AND VERTICAL JOINT DETAILS. IF CLIP SCREWS CANNOT BE PLACED DIRECTLY INTO SUPPORTING SUBGIRT OR STEEL STUD, ADDITIONAL STEEL MATERIAL MUST BE ADDED AT THE LOCATIONS TO CARRY CLIP SCREW FORCES INTO SUPPORTING STRUCTURE. PANEL CLIPS REQUIRE MINIMUM 18 GAUGE STEEL FOR ANCHORAGE EVERY 16" ON CENTER

2.4.7 1"x1"x $\frac{1}{8}$ " ALUMINUM TUBE STIFFENER (6063-T6) STIFFENER SPACING DETERMINED BU ENGINEERING FOR EACH PROJECT

2.4.8 DOW CORNING (R) 795 STRUCTURAL SILICONE FOR CONCEALED METAL TO METAL JOINTS

2.4.9 BETWEEN DISSIMILAR METALS USE A BITUMINOUS TAPE TO SEPARATE EXTRUSION FROM BUILDING SURFACE.

**2.5 FASTENER**

2.5.1 FASTENER TYPE AND SPACING DETERMINED BY ENGINEERING IF REQUIRED FOR EACH PROJECT. MAXIMUM 16" ON CENTER CLIP SPACING IF ENGINEERING IS NOT PROVIDED

2.5.2 FASTENERS MUST BE BI-METAL, CLIMASEAL COATED (OR EQUIVALENT COATING) OR STAINLESS STEEL TO BE COMPATIBLE WITH ALUMINUM COMPONENTS.

BASE DETAIL (OPTION 1)	1/3.01
BASE DETAIL (OPTION 2)	19/3.05
COMPOSITE COPING DETAIL (OPTION 3)	16/3.04
END WALL DETAIL	20/3.06
HEAD DETAIL @ WINDOW	6/3.02
HEAD DETAIL @ LOUVER	9/3.03
HEAD DETAIL @ DOOR	12/3.04
HORIZONTAL JOINT DETAIL	3/3.01
JAMB DETAIL @ WINDOW	8/3.02
JAMB DETAIL @ LOUVER	11/3.03
JAMB DETAIL @ DOOR	13/3.04
INSIDE CORNER DETAIL	4/3.01
OUTSIDE CORNER DETAIL	5/3.02
PARAPET COPING DETAIL (OPTION 1)	14/3.04
PARAPET COPING DETAIL (OPTION 2)	15/3.04
SILL DETAIL @ WINDOW	7/3.02
SILL DETAIL @ LOUVER	10/3.03
VERTICAL JOINT DETAIL	2/3.01
WALL TO SOFFIT TRANSITION (OPTION 1)	17/3.05
WALL TO SOFFIT TRANSITION (OPTION 2)	18/3.05

**2.7 GENERAL LAYOUT AND STIFFENER ARRANGEMENT (RECTANGLE/ SQUARE PANEL)**

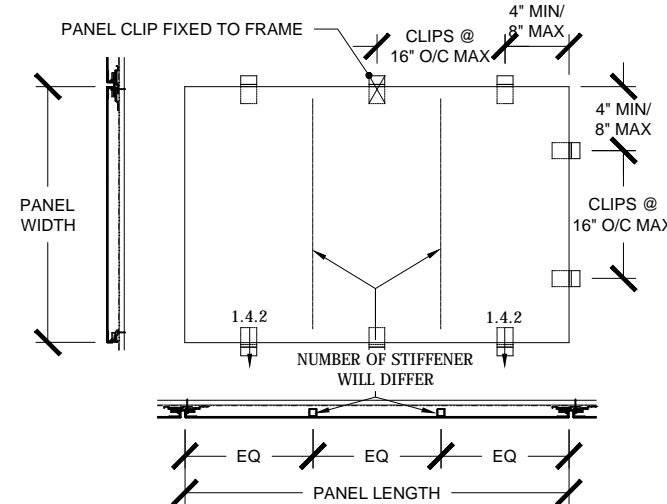

**2.8 GENERAL LAYOUT AND STIFFENER ARRANGEMENT (RADIUS PANEL)**

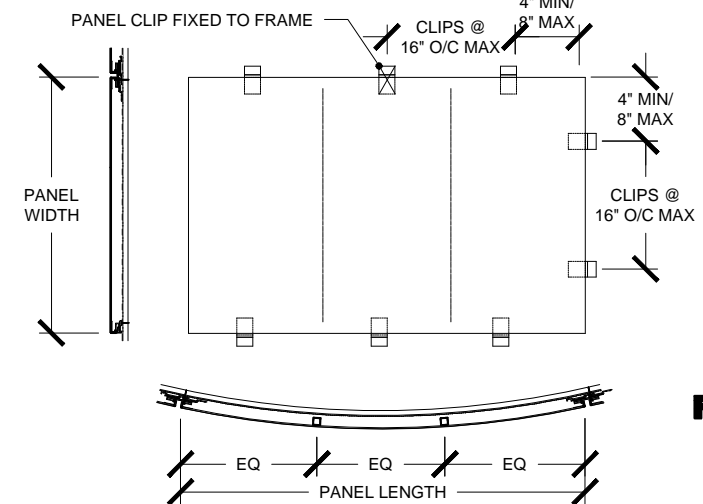

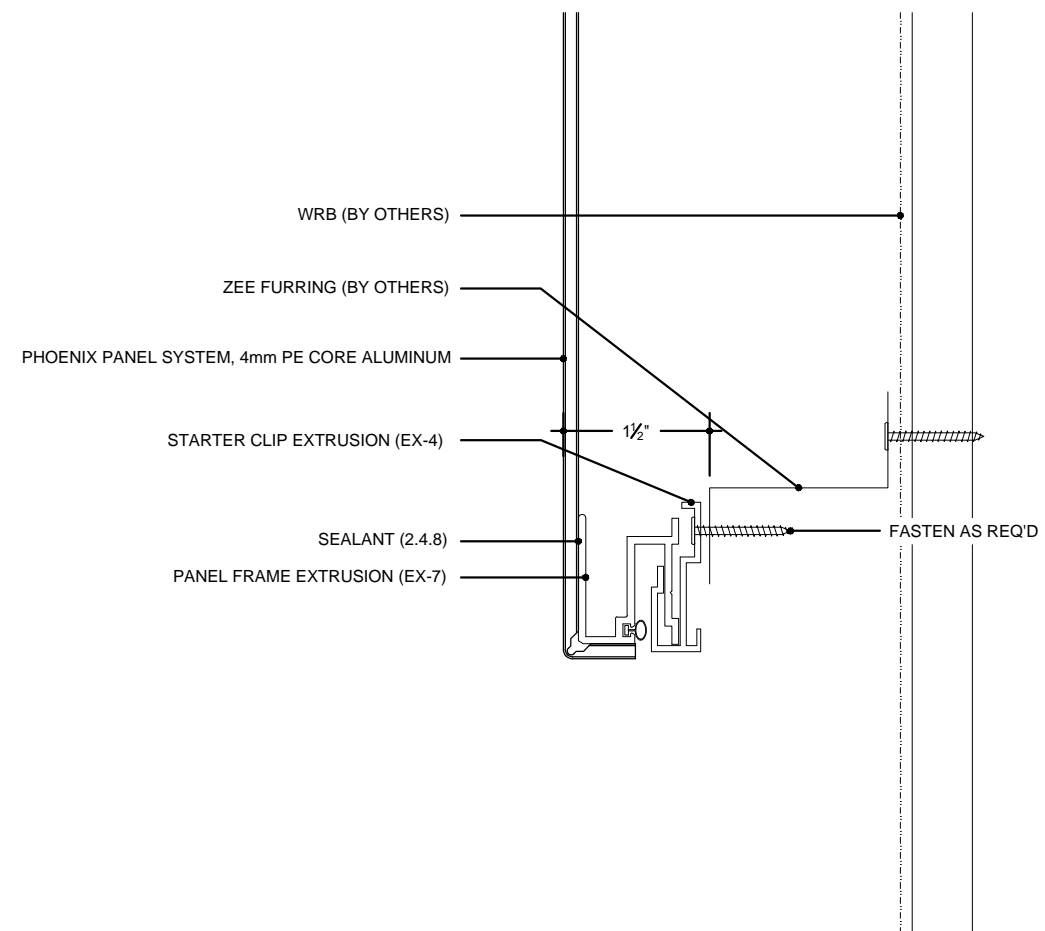

1 TYPICAL BASE DETAIL (OPTION 1)

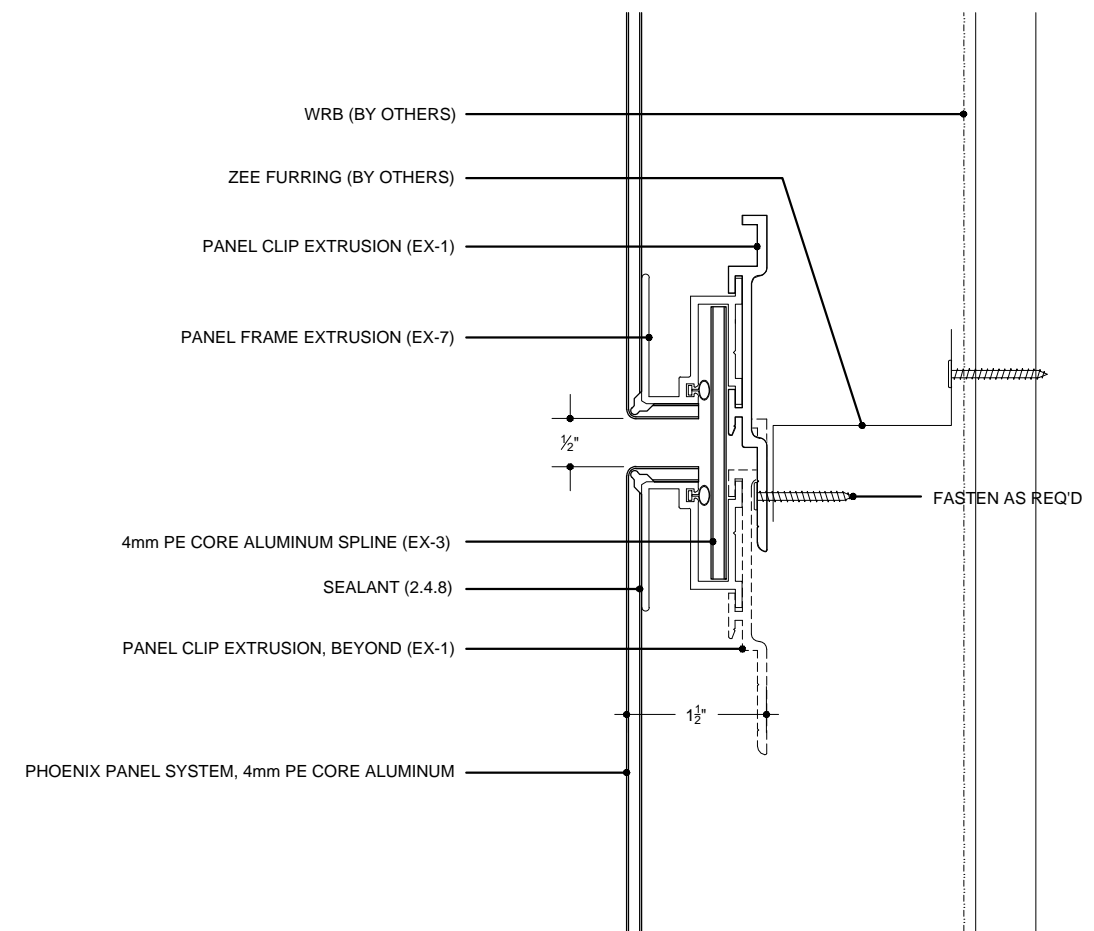

3 HORIZONTAL JOINT DETAIL

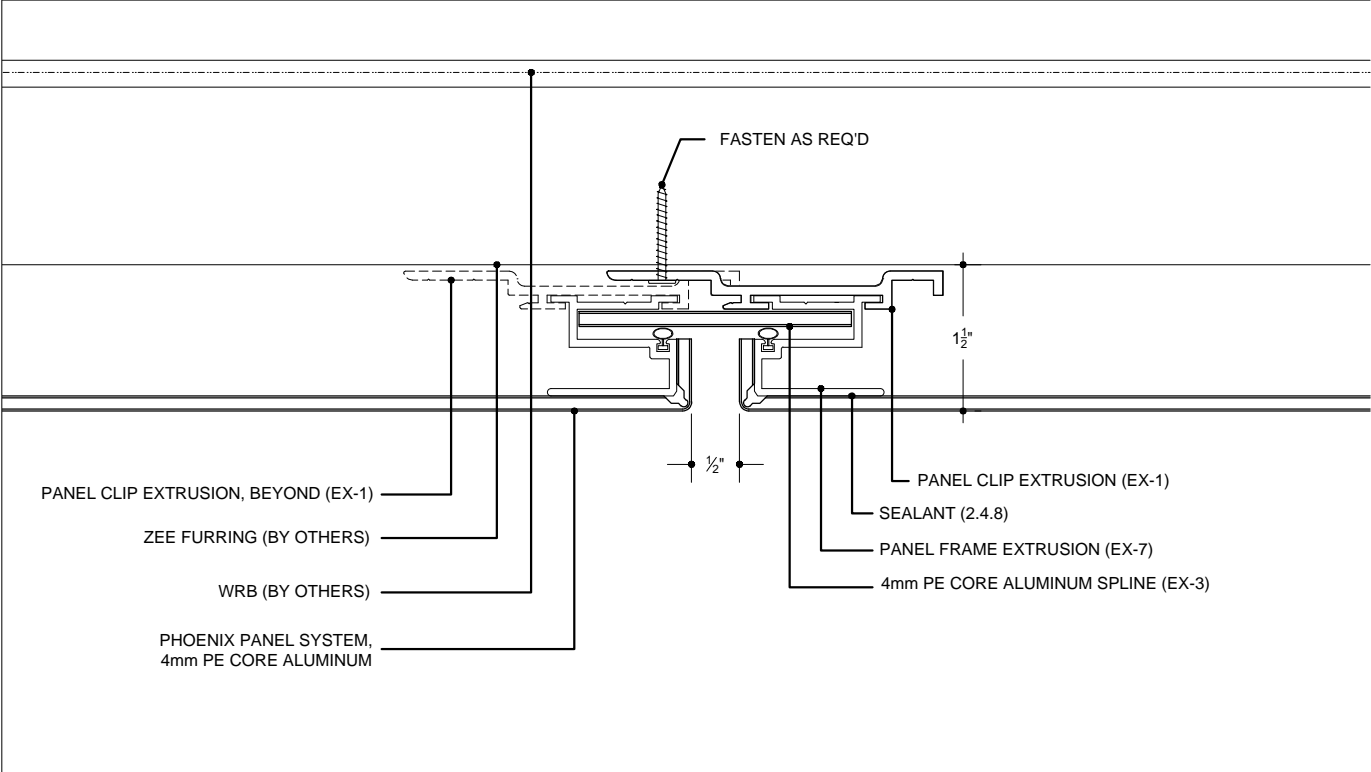

2 TYPICAL VERTICAL JOINT

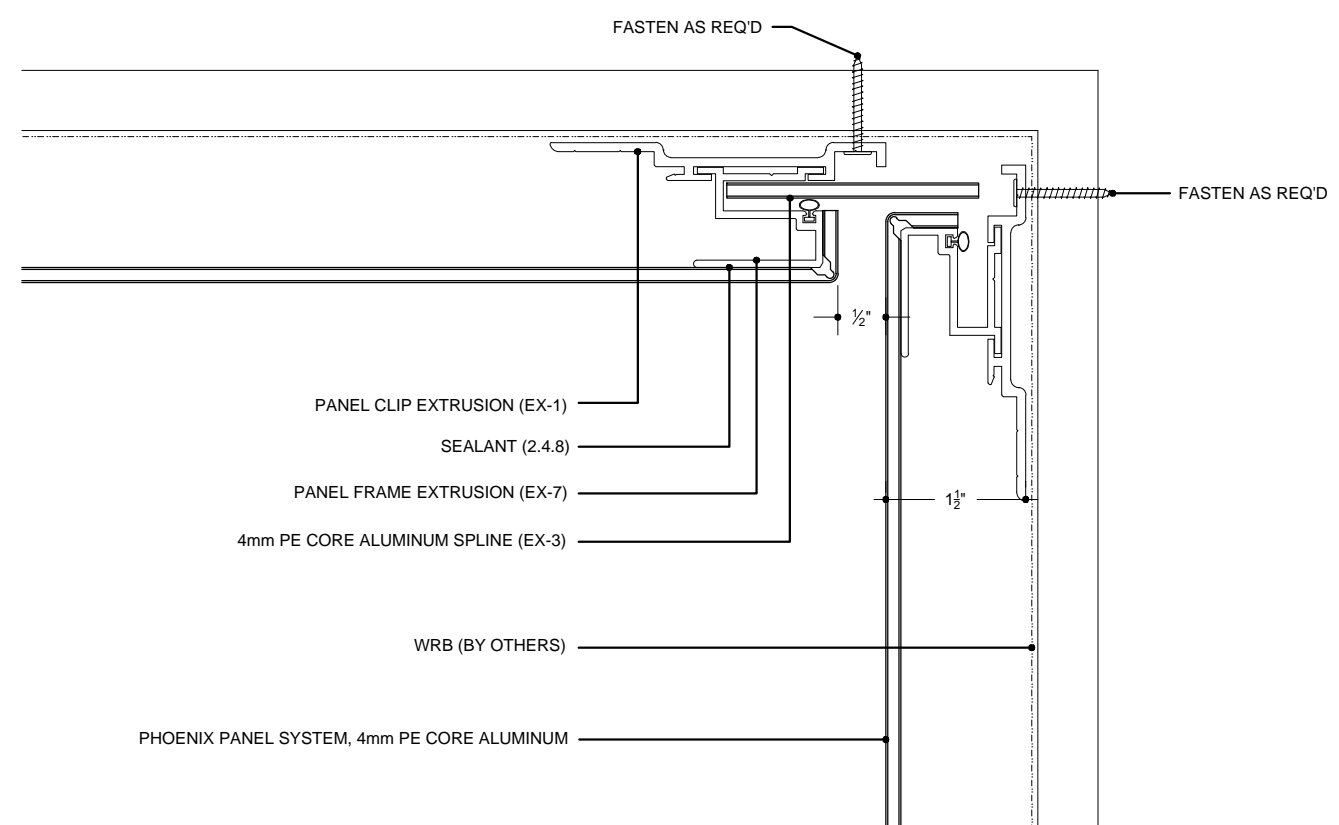

4 TYPICAL INSIDE CORNER

FIRM NAME & ADDRESS:



8650 Line Rd.  
Lynden, WA 98264  
p. 360-354-3155  
shane@phoenix-mw.net

**PHOENIX PANELS®**  
**"RISE SYSTEM"**

THE INFORMATION CONTAINED ON THIS DRAWING IS PROPRIETARY AND WILL NOT BE COPIED OR DISCLOSED TO OTHERS WITHOUT THE EXPRESS WRITTEN PERMISSION OF PHOENIX PANEL SYSTEM © 2015

GENERAL NOTES:

PROJECT:  
**PHOENIX PANEL SYSTEM**  
**TYPICAL DETAILS**

DATE:  
**12/10/15**

SCALE:

REVISION:

SHEET:

DRAWN BY:

**3.01**

FIRM NAME & ADDRESS:



8650 Line Rd.  
Lynden, WA 98264  
p. 360-354-3155  
shane@phoenix-mw.net

**PHOENIX PANELS®  
"RISE SYSTEM"**

THE INFORMATION CONTAINED ON THIS DRAWING IS PROPRIETARY AND WILL NOT BE COPIED OR DISCLOSED TO OTHERS WITHOUT THE EXPRESS WRITTEN PERMISSION OF PHOENIX PANEL SYSTEM © 2015

GENERAL NOTES:

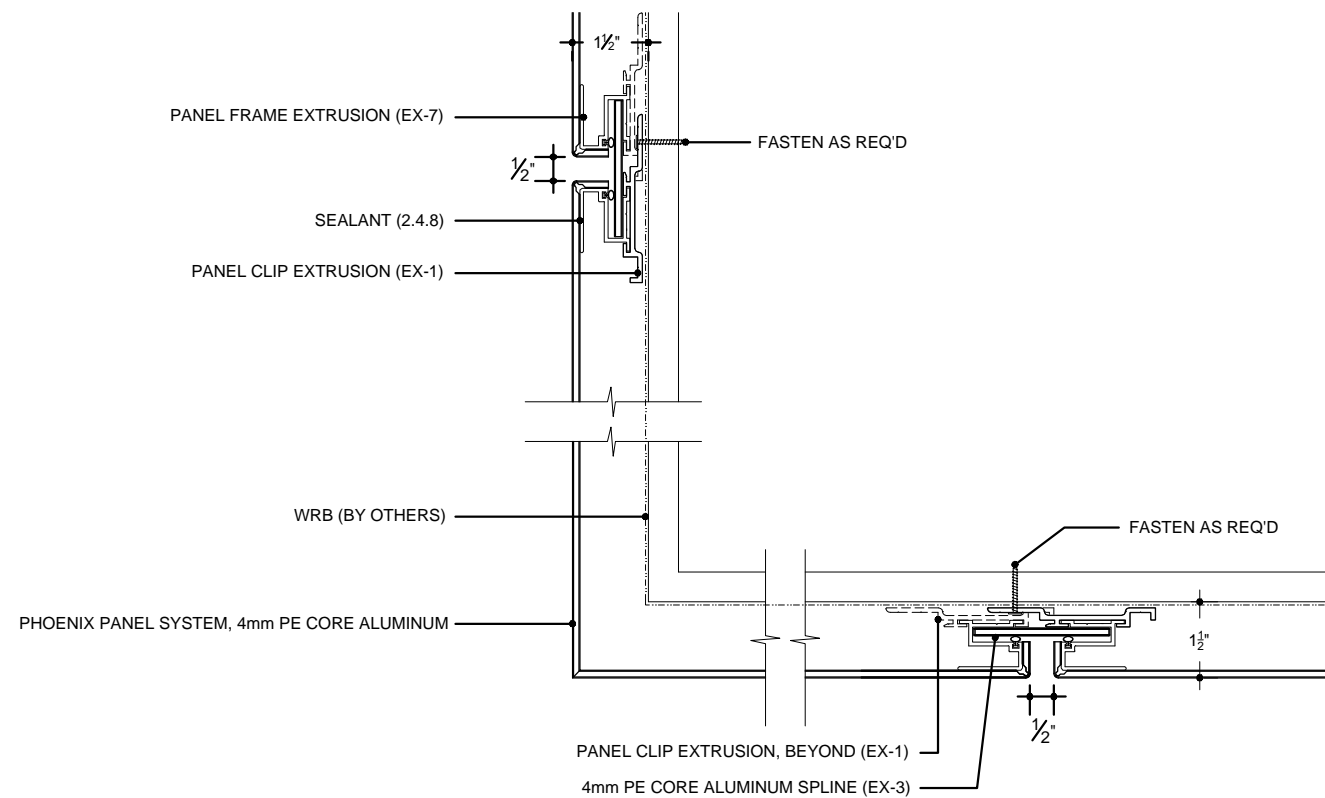

5 TYPICAL OUTSIDE CORNER DETAIL

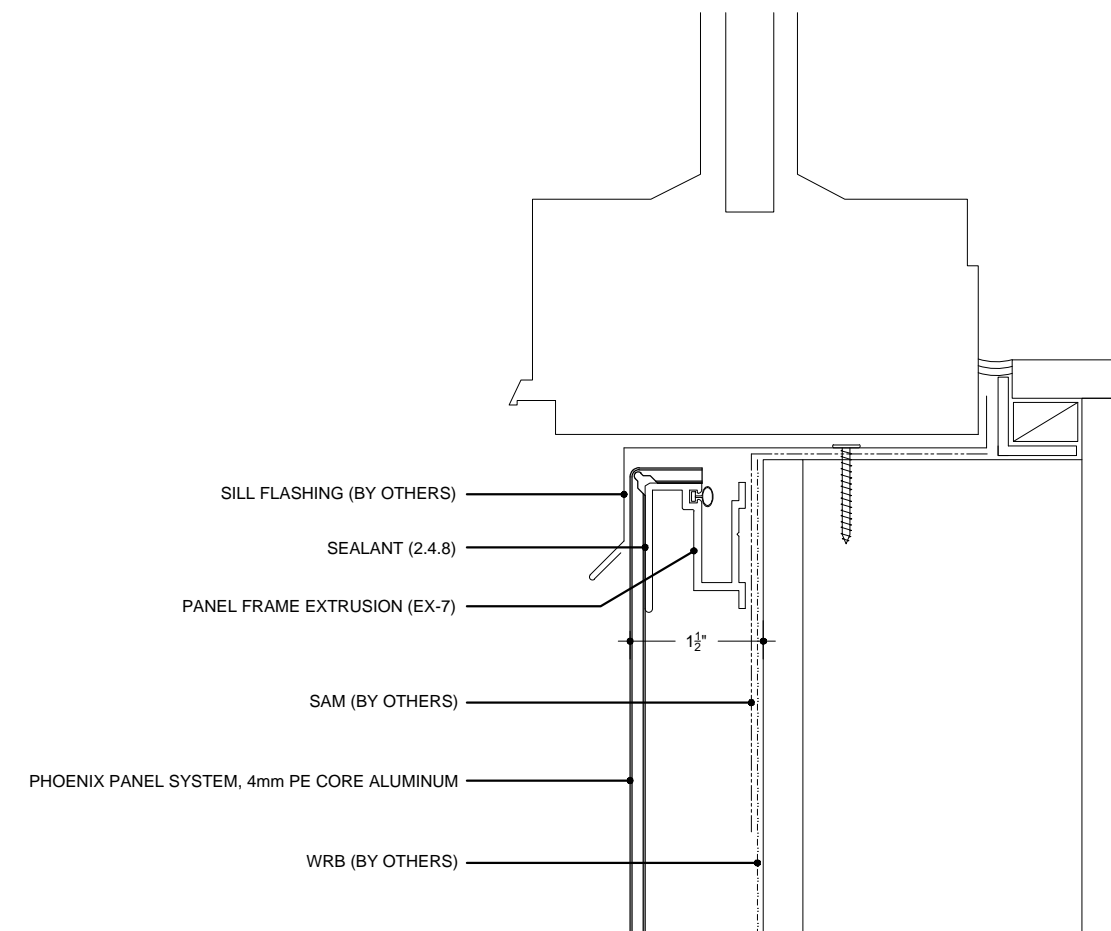

7 TYPICAL SILL DETAIL @ WINDOW

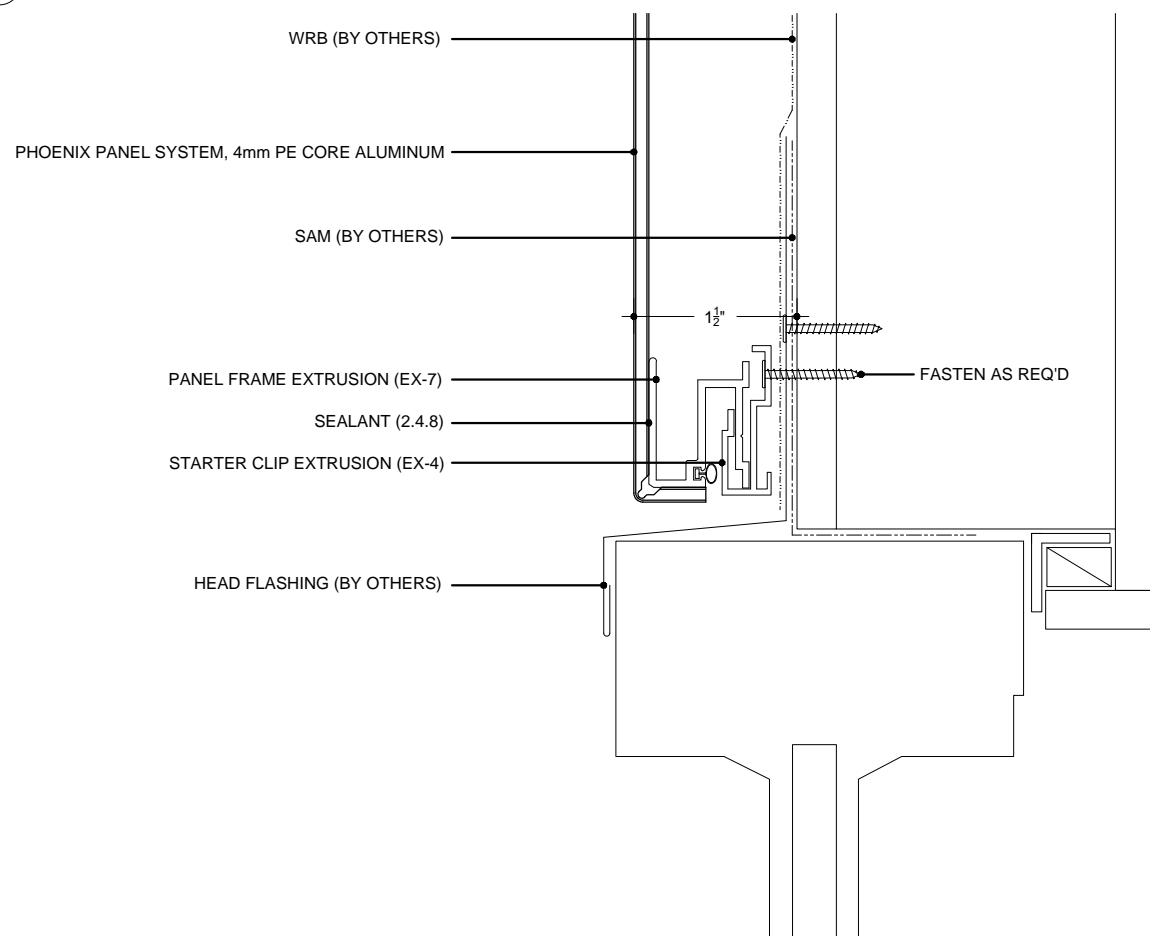

6 TYPICAL HEAD DETAIL @ WINDOW

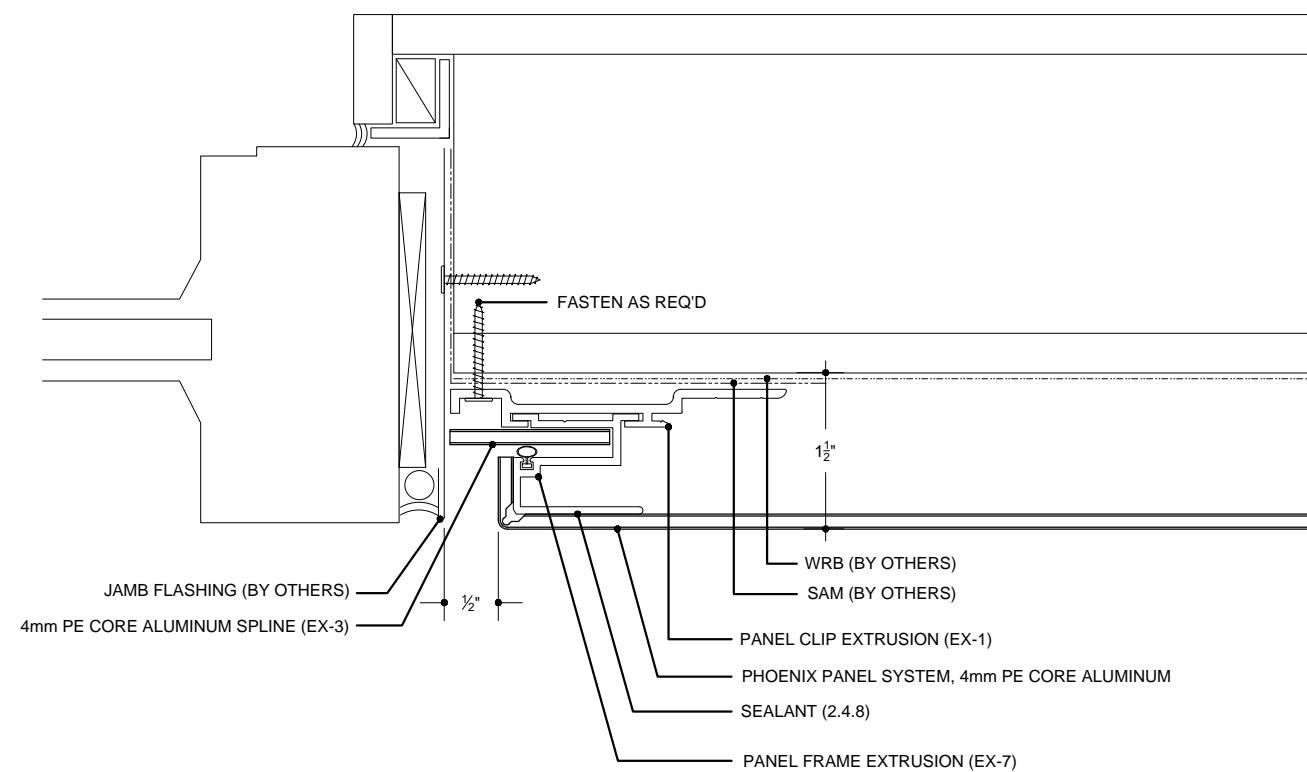

8 TYPICAL JAMB DETAIL @ WINDOW

PROJECT:  
**PHOENIX PANEL SYSTEM  
TYPICAL DETAILS**

DATE:  
**12/10/15**

SCALE:

REVISION:

SHEET:

DRAWN BY:

**3.02**

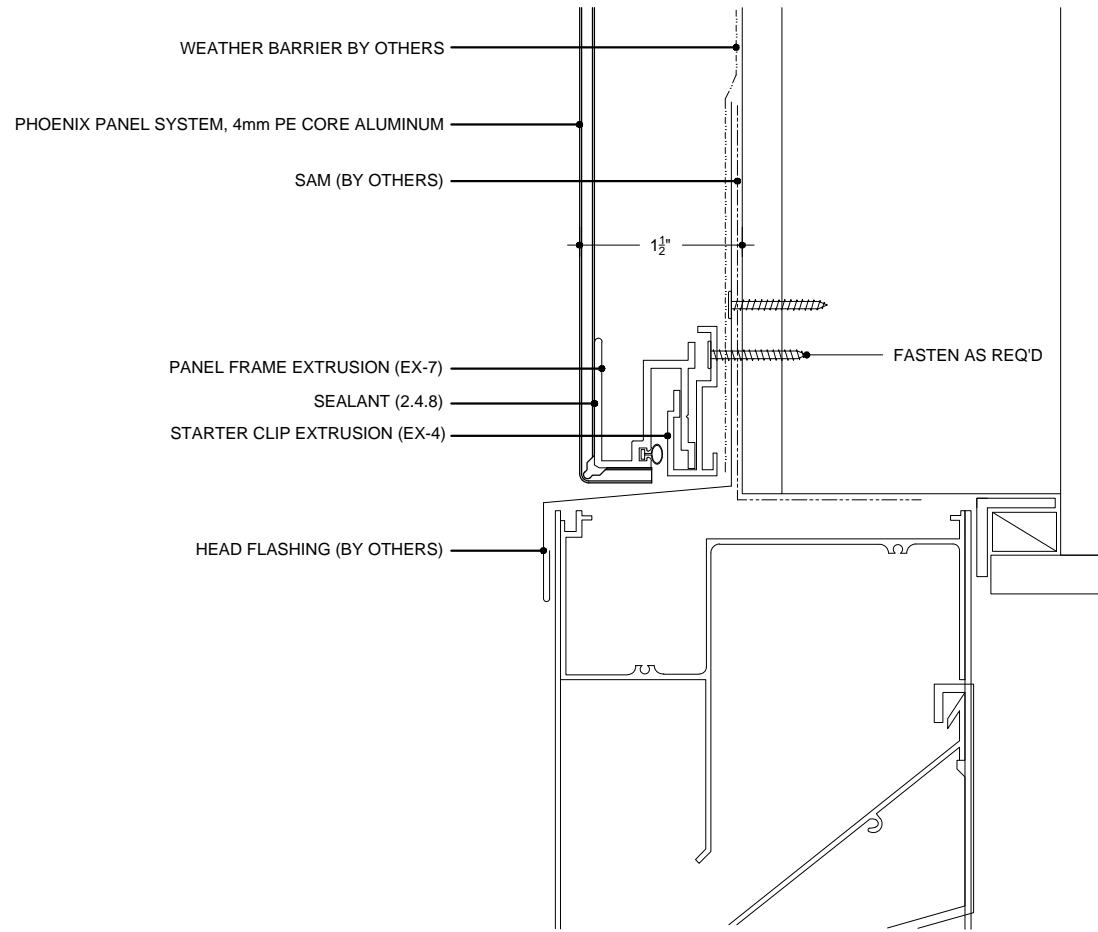

9 TYPICAL HEAD DETAIL @ LOUVER

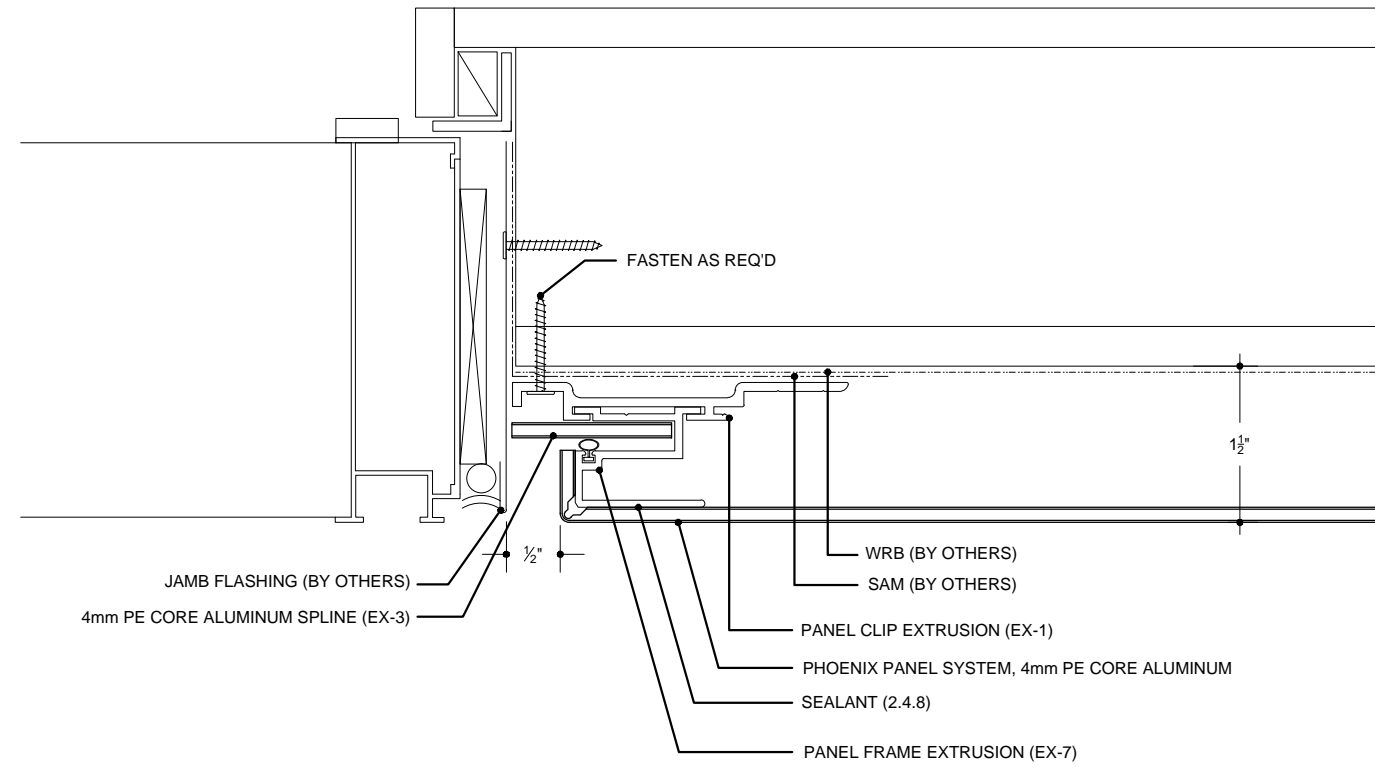

11 TYPICAL JAMB DETAIL @ LOUVER

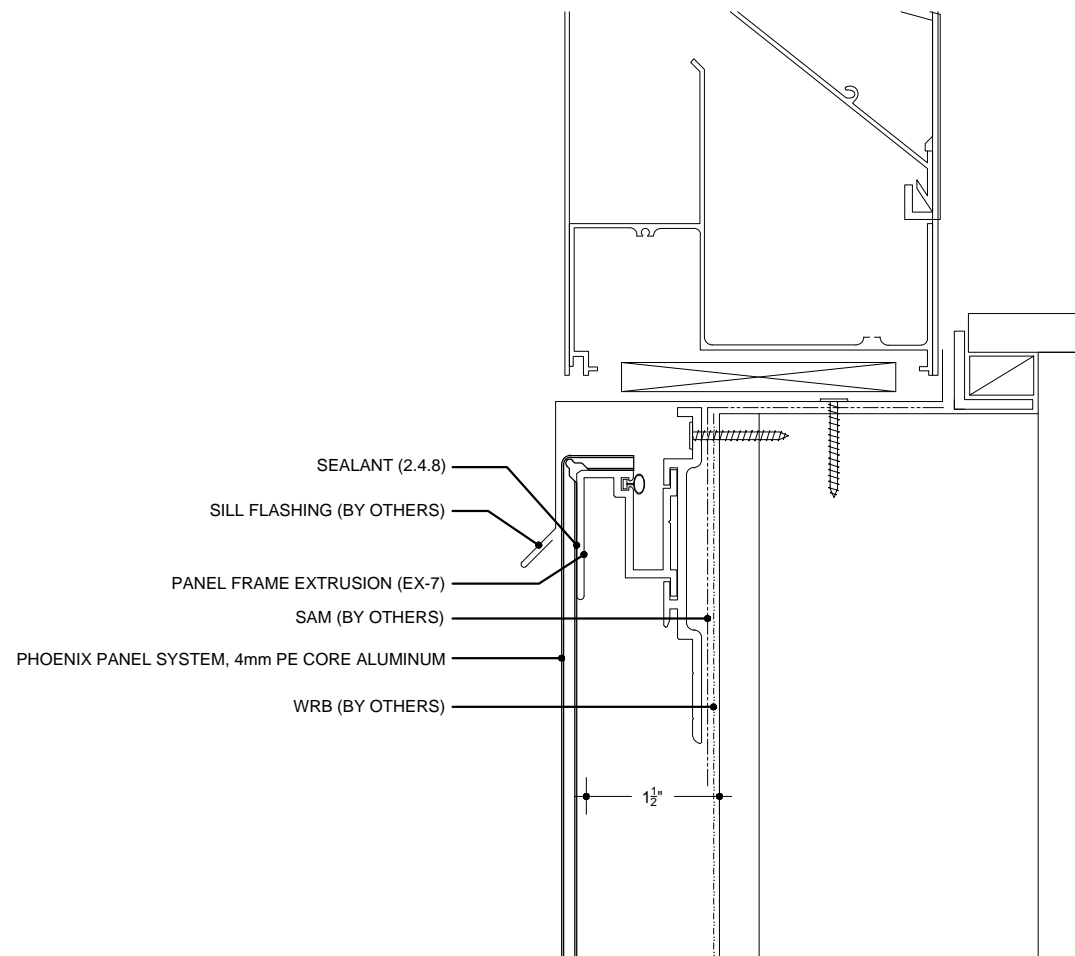

10 TYPICAL SILL DETAIL @ LOUVER

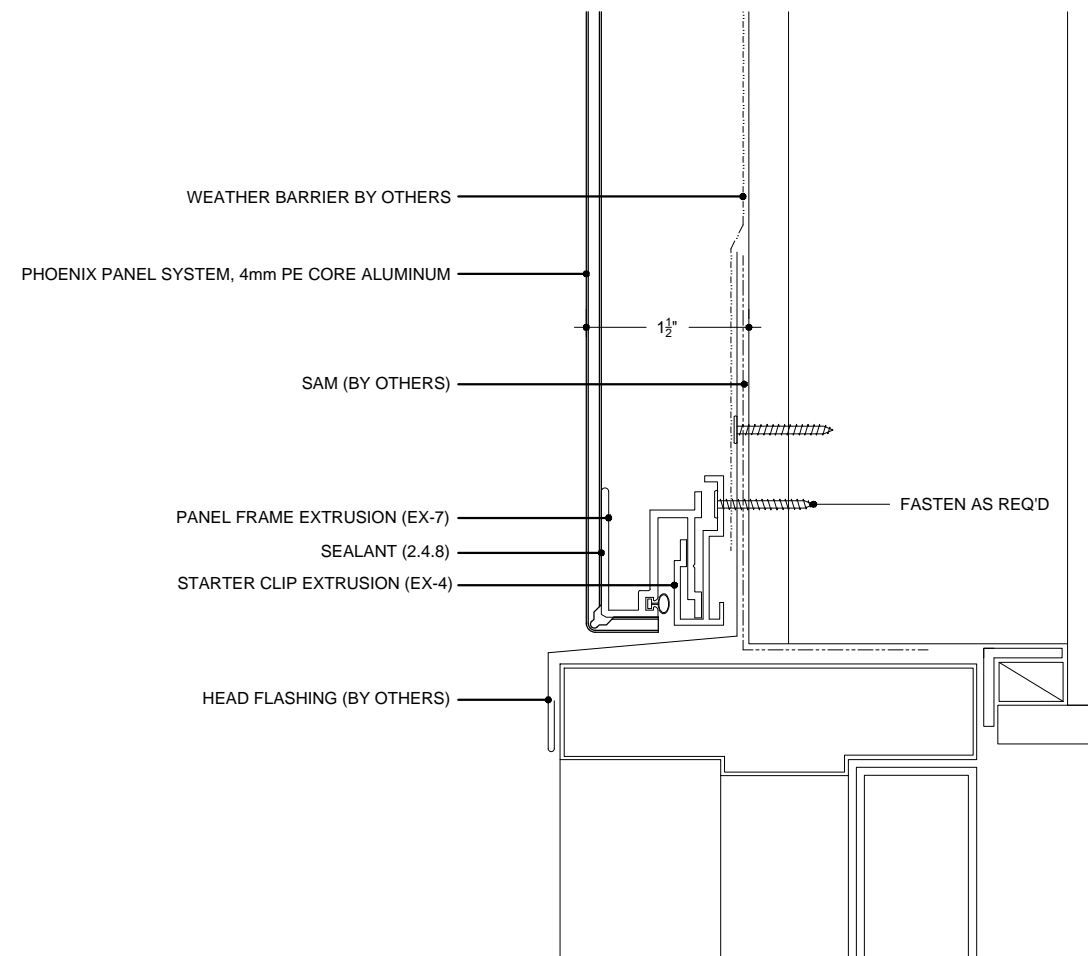

12 TYPICAL HEAD DETAIL @ DOOR

FIRM NAME & ADDRESS:



8650 Line Rd.  
Lynden, WA 98264  
p. 360-354-3155  
shane@phoenix-mw.net

PHOENIX PANELS®  
"RISE SYSTEM"

THE INFORMATION CONTAINED ON THIS DRAWING IS PROPRIETARY AND WILL NOT BE COPIED OR DISCLOSED TO OTHERS WITHOUT THE EXPRESS WRITTEN PERMISSION OF PHOENIX PANEL SYSTEM © 2015

GENERAL NOTES:

PROJECT:  
PHOENIX PANEL SYSTEM  
TYPICAL DETAILS

DATE:  
12/10/15

SCALE:

REVISION:

SHEET:

DRAWN BY:

3.03

FIRM NAME & ADDRESS:



8650 Line Rd.  
Lynden, WA 98264  
p. 360-354-3155  
shane@phoenix-mw.net

**PHOENIX PANELS®  
"RISE SYSTEM"**

THE INFORMATION CONTAINED ON THIS DRAWING IS  
PROPRIETARY AND WILL NOT BE COPIED OR DISCLOSED  
TO OTHERS WITHOUT THE EXPRESS WRITTEN  
PERMISSION OF PHOENIX PANEL SYSTEM © 2015

GENERAL NOTES:

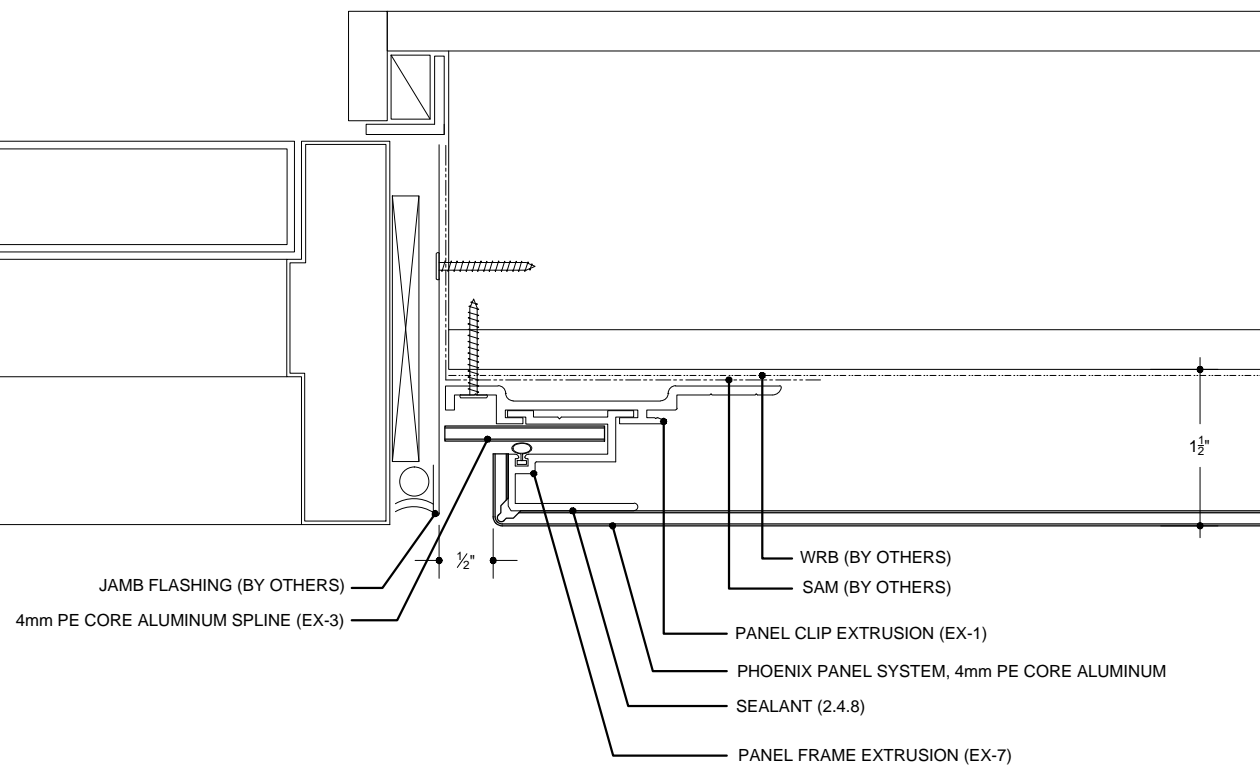

13 TYPICAL JAMB DETAIL @ DOOR

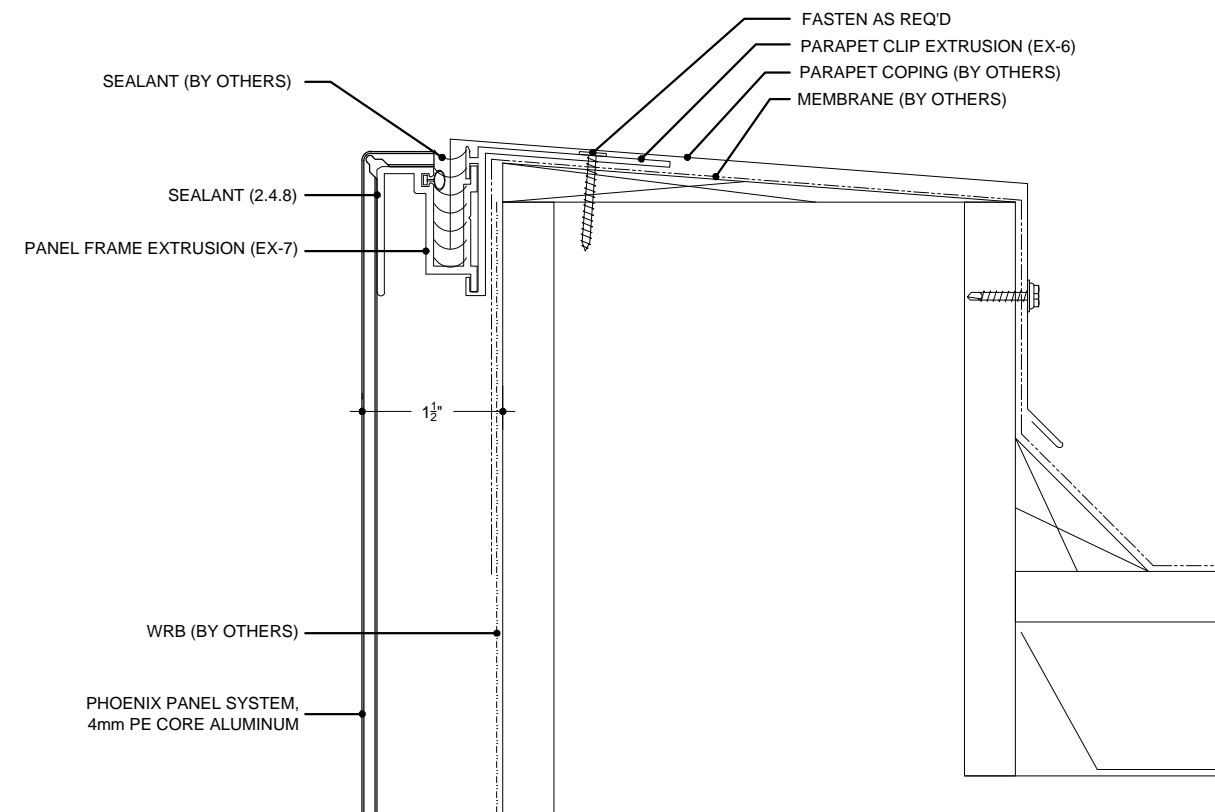

15 TYPICAL PARAPET COPING DETAIL (OPTION 2)

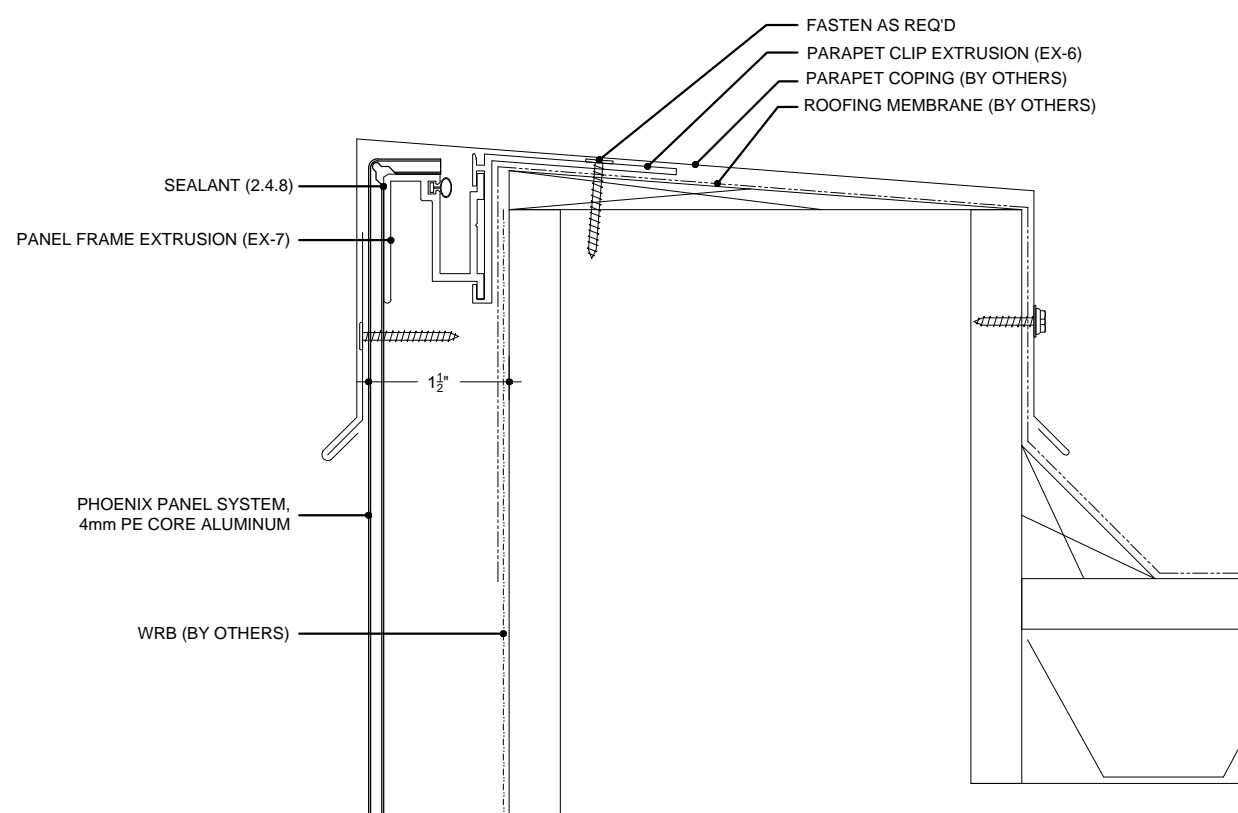

14 TYPICAL PARAPET COPING DETAIL (OPTION 1)

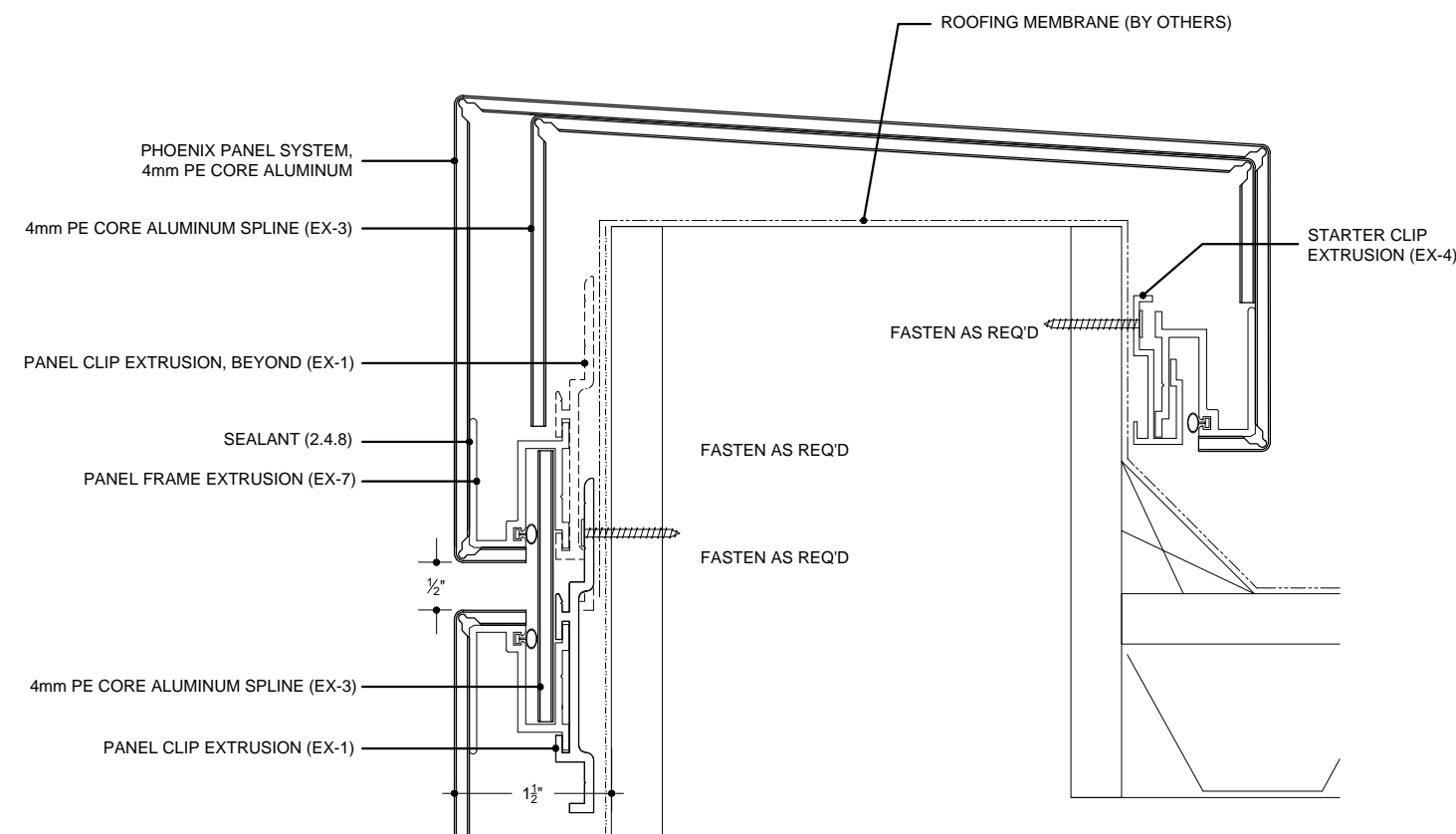

16 TYPICAL COMPOSITE COPING DETAIL

PROJECT:  
**PHOENIX PANEL SYSTEM  
TYPICAL DETAILS**

DATE:  
**12/10/15**

SCALE:

REVISION:

SHEET:

DRAWN BY:

**3.04**

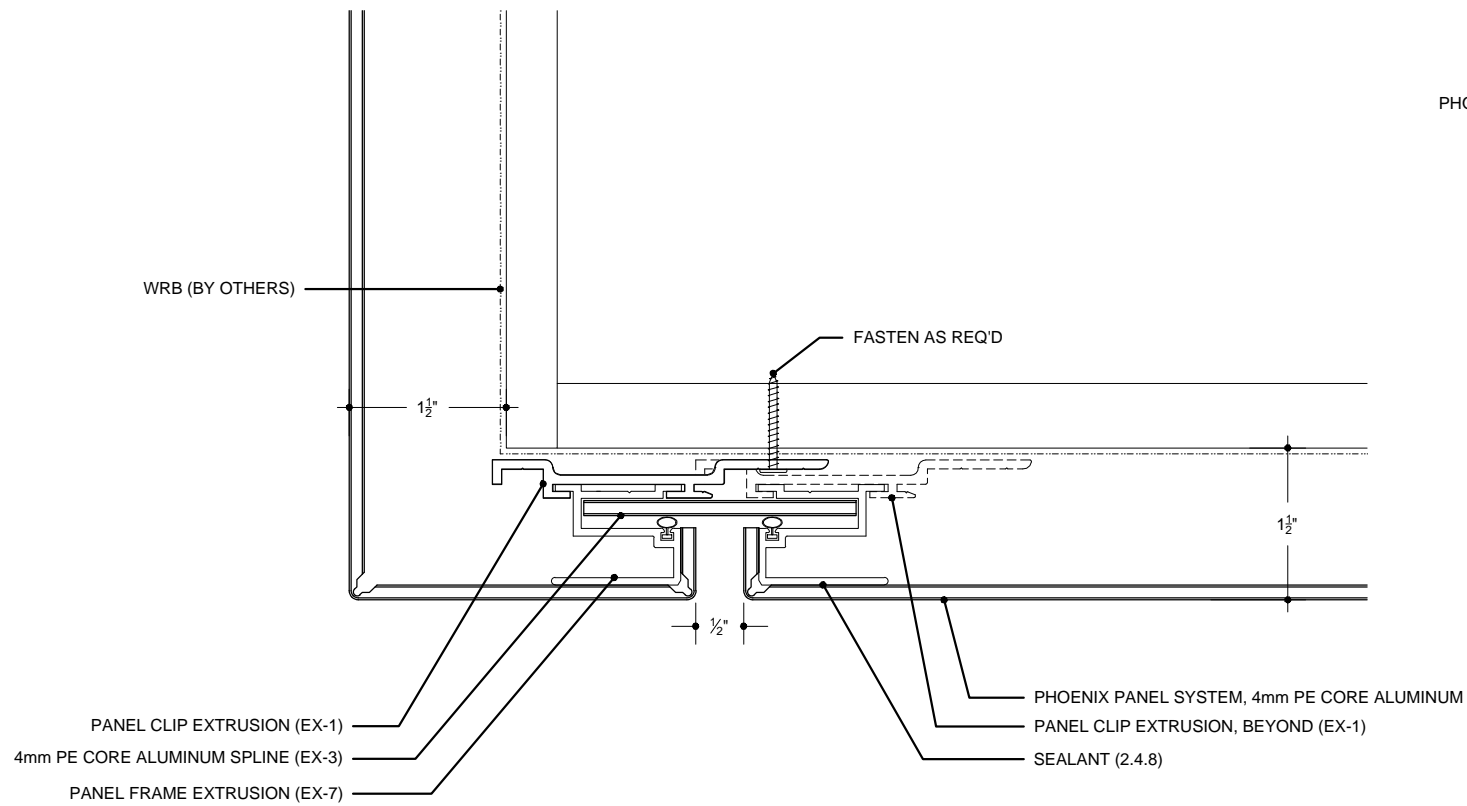

17 TYPICAL WALL TO SOFFIT TRANSITION DETAIL(OPTION 1)

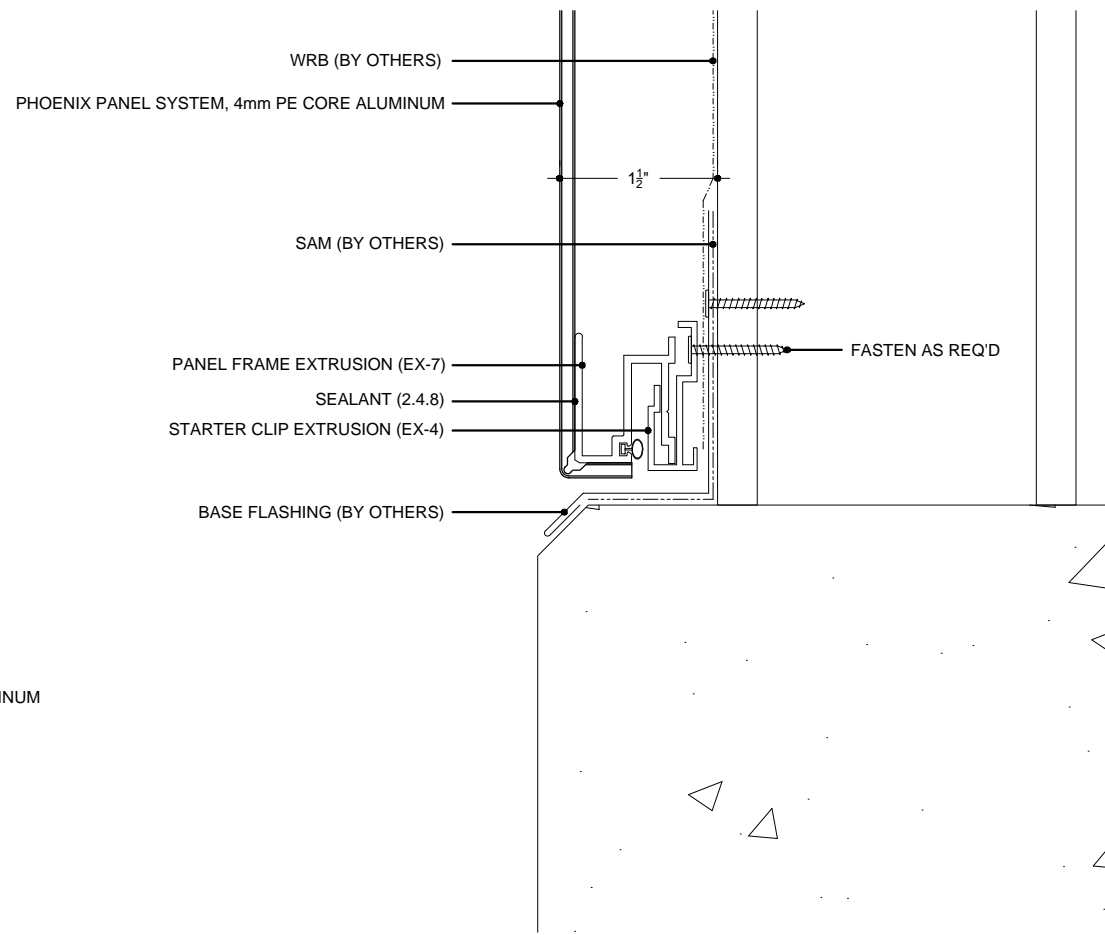

19 TYPICAL BASE DETAIL (OPTION 2)

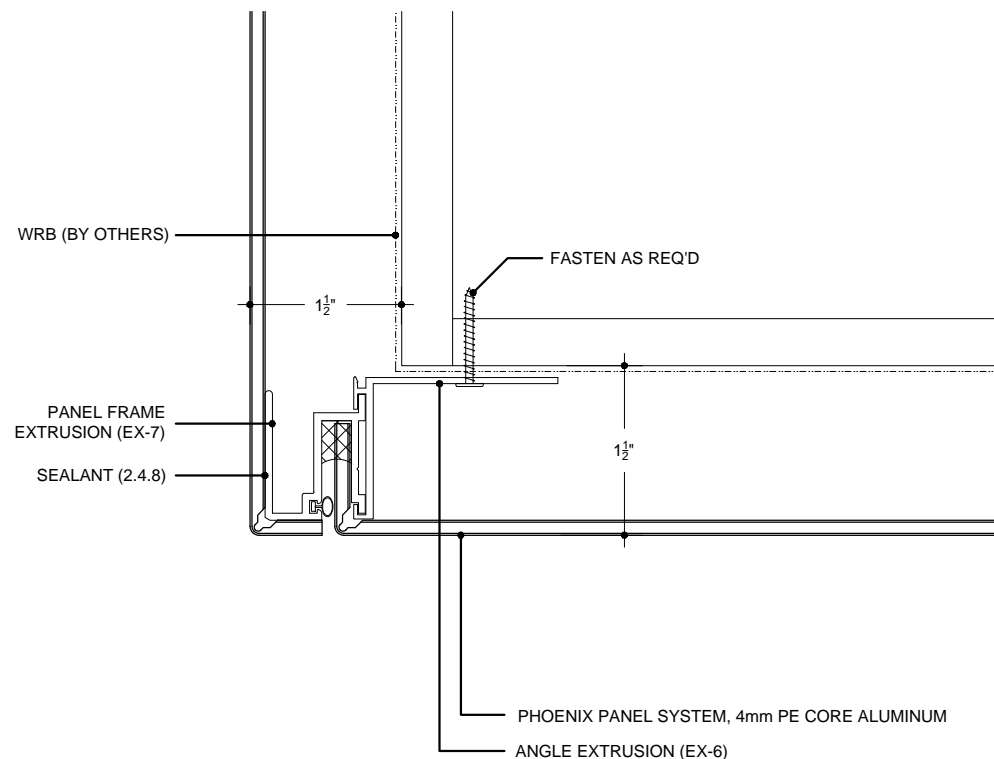

18 TYPICAL WALL TO SOFFIT TRANSITION ("TUCK IN" OPTION 2)

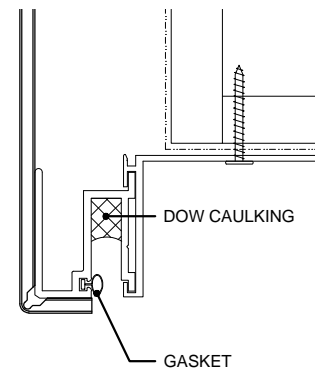

1. PLACE BEAD OF DOW CAULKING BEHIND GASKET

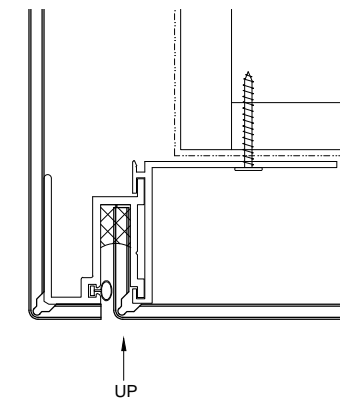

2. PUSH COMPOSITE PANEL INTO EXTRUSION POCKET. PANEL FACE AND EXTRUSION SHOULD BE FLUSH

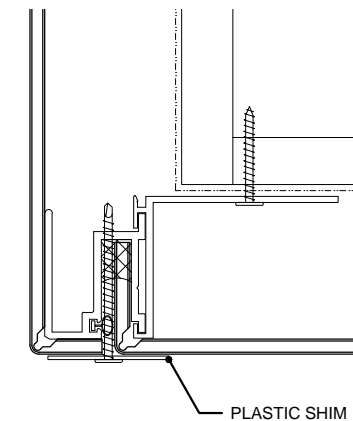

3. USE A SELF TAPPING FASTENER, SCREW THROUGH PLASTIC SHIM TO HOLD UNTIL CAULKING CURES. (72hrs) AFTER CAULKING CURES REMOVE SCREW AND PLASTIC SHIM.

FIRM NAME & ADDRESS:



8650 Line Rd.  
Lynden, WA 98264  
p. 360-354-3155  
shane@phoenix-mw.net

**PHOENIX PANELS®**  
**"RISE SYSTEM"**

THE INFORMATION CONTAINED ON THIS DRAWING IS PROPRIETARY AND WILL NOT BE COPIED OR DISCLOSED TO OTHERS WITHOUT THE EXPRESS WRITTEN PERMISSION OF PHOENIX PANEL SYSTEM © 2015

GENERAL NOTES:

PROJECT:  
**PHOENIX PANEL SYSTEM**  
**TYPICAL DETAILS**

DATE:  
**12/10/15**

SCALE:

REVISION:

SHEET:

DRAWN BY:

**3.05**

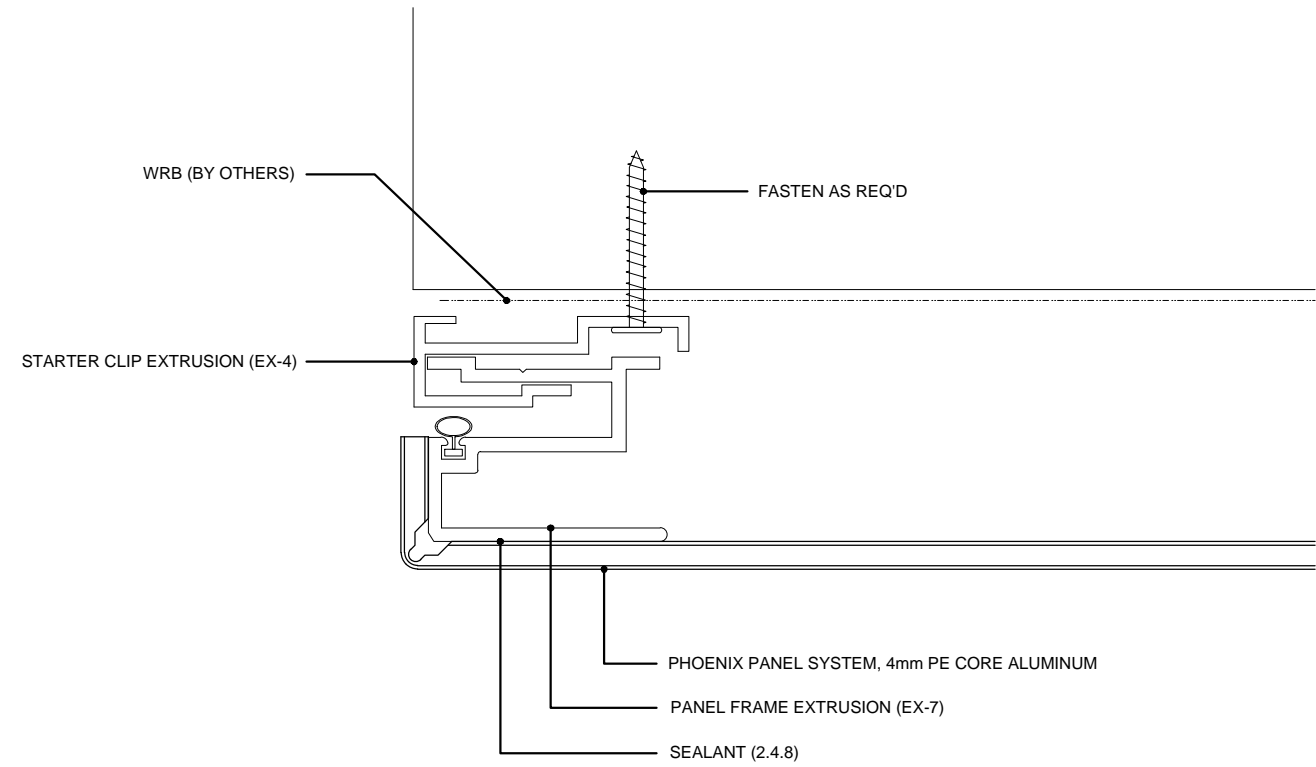

20 END WALL DETAIL

FIRM NAME & ADDRESS:



8650 Line Rd.  
 Lynden, WA 98264  
 p. 360-354-3155  
 shane@phoenix-mw.net

**PHOENIX PANELS®**  
**"RISE SYSTEM"**

THE INFORMATION CONTAINED ON THIS DRAWING IS PROPRIETARY AND WILL NOT BE COPIED OR DISCLOSED TO OTHERS WITHOUT THE EXPRESS WRITTEN PERMISSION OF PHOENIX PANEL SYSTEM © 2015

GENERAL NOTES:

PROJECT:  
**PHOENIX PANEL SYSTEM  
 TYPICAL DETAILS**

DATE:  
**12/10/15**

SCALE:

REVISION:

SHEET:

DRAWN BY:

**3.06**