

TEST REPORT

Report No.: E5985.01-901-44

Rendered to:

PHOENIX METALWORKS, LLC
D/B/A PHOENIX PANELS
Lynden, Washington

PRODUCT TYPE: Wall Cladding System
SERIES/MODEL: Phoenix Rise

AAMA 508-07, Voluntary Test Method and Specification for Pressure Equalized Rain Screen Wall Cladding Systems



Test Dates: 03/18/15
Through: 03/24/15
Test Record Retention Date: 03/24/19
Report Date: 04/02/15

1.0 Report Issued To: Phoenix Metalworks, LLC
d/b/a Phoenix Panels
8650 Line Road
Lynden, WA 98264

2.0 Test Laboratory: Architectural Testing, Inc.,
a subsidiary of Intertek (Intertek-ATI)
22155 68th Ave. South
Kent, Washington 98032
253-395-5656

3.0 Project Summary:

3.1 Product Type: Wall Cladding System

3.2 Series/Model: Phoenix Rise

3.3 Compliance Statement: Results obtained are tested values and were secured by using the designated test method(s). Test specimen description and results are reported herein.

3.4 Test Dates: 03/18/15 – 03/24/15

3.5 Test Location: Intertek-ATI facility located in Kent, Washington.

3.6 Test Sample Source: The test specimen was provided by the client.

3.7 Drawing Reference: The test specimen drawings have been reviewed by Intertek-ATI and are representative of the test specimen reported herein. Test specimen construction was verified by Intertek-ATI per the drawings located in the appropriate Appendix. Any deviations are documented herein or on the drawings.

3.8 List of Official Observers:

<u>Name</u>	<u>Company</u>
Brian Rasmussen	Intertek-ATI
Chris Wilson	Intertek-ATI

4.0 Test Method(s):

AAMA 508-07, *Voluntary Test Method and Specification for Pressure Equalized Rain Screen Wall Cladding Systems.*

ASTM E 283-04, *Standard Test Method for Determining Rate of Air Leakage Through Exterior Windows, Curtain Walls, and Doors Under Specified Pressure Differences Across the Specimen.* Testing was conducted at 75 Pa (1.57 psf) positive static air pressure difference.

4.0 Test Method(s): (Continued)

ASTM E 1233-06 (Modified), *Standard Test Method for Structural Performance of Exterior Windows, Doors, Skylights, and Curtain Walls by Cyclic Static Air Pressure Differential*. Testing was conducted for 100, three-second cycles from 240 Pa (5.0 psf) to 1200 Pa (25.0 psf) to 240 Pa (5.0 psf).

ASTM E 331-00, *Standard Test Method for Water Penetration of Exterior Windows, Skylights, Doors, and Curtain Walls, by Uniform Static Air Pressure Difference*. Testing was conducted at 300 Pa (6.24 psf) positive static air pressure difference for a 15-minute duration. Water was applied to the mock-up at a minimum rate of 5 gal/hr/ft².

AAMA 501.1-05, *Standard Test Method for Water Penetration of Windows, Curtain Walls, and Doors Using Dynamic Pressure*. Testing was conducted with a dynamic pressure equivalent of 300 Pa (6.24 psf) for a 15-minute duration. Water was applied to the mock-up at a minimum rate of 5 gal/hr/ft².

5.0 Test Specimen Description:

5.1 Product Sizes:

Overall Area: 5.9 m ² (64.0 ft ²)	Width		Height	
	millimeters	inches	millimeters	inches
Overall size	2438	96	2438	96
Panel size (4)	1205	47-7/16	1197	47-1/8

5.2 Panel Construction: The test specimen was constructed of four 4 mm (0.15") thick Phoenix Panel Systems composite panels. The bottom of each panel utilized 4.8 mm (3/16") diameter weeps, two per panel.

5.3 Test Wall Construction: The 96" wide by 96" high test wall was constructed of 2 x 6 Douglas Fir wood studs. The studs were spaced 16" on center inside a 2 x 8 wood buck. The stud wall was covered with 3/16" thick clear polycarbonate and sealed and secured to the exterior of the wall to simulate an air/water barrier. The wall panel system was then installed onto the clear polycarbonate in a manner consistent with normal construction procedures for the system. The clear polycarbonate was calibrated to a pre-determined air leakage rate by drilling 1/8" diameter holes on the back side in a uniform pattern, making sure to create an even pressure drop and leakage rate across the wall.

5.0 Test Specimen Description: (Continued)

5.4 Reinforcement: One extruded aluminum tube stiffener, 25 mm x 25 mm (1" x 1"), was adhered to the center of each panel with adhesive sealant.

5.5 Installation: Installation of the tested product was performed by the client.

The panels were installed in a bottom-to-top and left-to-right order. The perimeter of the panel system utilized metal flashing and extruded aluminum clips, secured to the perimeter with #8 x 1-1/4" long screws and spaced approx. 16" on center.

The panels were secured to each stud at the interior horizontal edge with extruded aluminum clips. The clips were secured, one to each stud, with one #8 by 1-1/4" screw.

Three extruded aluminum clips were evenly spaced along each panel edge at the vertical joint and secured to the center stud with one #8 by 1-1/4" screw each.

5.6 Cavity Depth: 32 mm (1-1/4")

5.7 Vent Area (Weeps): 0.0001 m² (0.22 in²)

5.8 Air Cavity Volume to Vent Area Ratio: 1429.6 m³/m² (435.8 ft³/ft²)

6.0 Test Results: The temperature during testing was approximately 21°C (70°F). The results are tabulated as follows:

Air Leakage (Infiltration per ASTM E 283)

Pressure	Results	Allowed	Note
75 Pa (1.57 psf)	0.56 L/s/m ² (0.11 cfm/ft ²)	0.5 L/s/m ² (0.11 cfm/ft ²) min. 0.7 L/s/m ² (0.13 cfm/ft ²) max.	1

Pressure Cycling (per ASTM E 1233)

100 cycles from 240 Pa (5 psf) to 1200 Pa (25 psf) to 240 Pa (5 psf)

Compartment	Results	Allowed	Note
Cycle Time Lag	0.01 sec.	0.08 sec. max.	2
Cycle Pressure Difference	120 Pa (2.5 psf)	600 Pa (12.5 psf) max.	
PASS / FAIL	PASS	-----	

6.0 Test Results: (Continued)

Static Water Penetration (per ASTM E 331)

Pressure	Results	Allowed	Note
300 Pa (6.24 psf)	0.25 m ² (2.66 ft ²)	0.30 m ² (3.20 ft ²)	3
PASS / FAIL	PASS	-----	

Dynamic Water Penetration (per AAMA 501.1)

Pressure	Results	Allowed	Note
300 Pa (6.24 psf)	0.08 m ² (0.88 ft ²)	0.30 m ² (3.20 ft ²)	3
PASS / FAIL	PASS	-----	

Note #1: The calibrated leakage was achieved with 1/8" diameter holes drilled through the polycarbonate. All holes were evenly distributed in each stud cavity and located 6" above the bottom and the mid-span of the wall. A pressure tap was attached through the air barrier at the right side of the system.

Note #2: Reference Appendix A.

Note #3: Water on the polycarbonate air/water barrier surface was present at the intersection of horizontal and vertical joints in the form of mist or droplets.

General Note: All testing was performed in accordance with the referenced standards. This report is not intended as a comprehensive evaluation of the system regarding performance and application to specific buildings.

7.0 Test Equipment:

- Computerized control panel to run positive pressures, cyclic pressures, and measure air leakage rates.
- Structural test chamber to mount the test wall in, so as to evaluate the performance of the wall panel system for static and cyclic pressures, as well as water penetration. The wall was situated such that the interior side of the test wall was accessible to observe air and water leakage.
- Dynamic wind generator to create a wind pressure to test the wall panel system for dynamic water penetration.
- Computerized data management equipment to read, log, and graph differential pressures.

The service life of this report will expire on the stated Test Record Retention End Date, at which time such materials as drawings, data sheets, samples of test specimens, copies of this report, and any other pertinent project documentation, shall be discarded without notice.

If the test specimen contains glazing, no conclusions of any kind regarding the adequacy or inadequacy of the glass in any glazed test specimen(s) can be made. This report does not constitute certification of this product nor an opinion or endorsement by this laboratory. It is the exclusive property of the client so named herein and relates only to the specimen tested. This report may not be reproduced, except in full, without the written approval of Intertek-ATI

For Intertek-ATI:

Brian L. Rasmussen
Technician

Jeffrey L. Dideon
Director – Regional Operations

BLR:pac

Attachments (pages): This report is complete only when all attachments listed are included.

- Appendix-A: Graph (1)
- Appendix-B: Photographs (1)
- Appendix-C: Drawings (3)

Appendix A

Graph

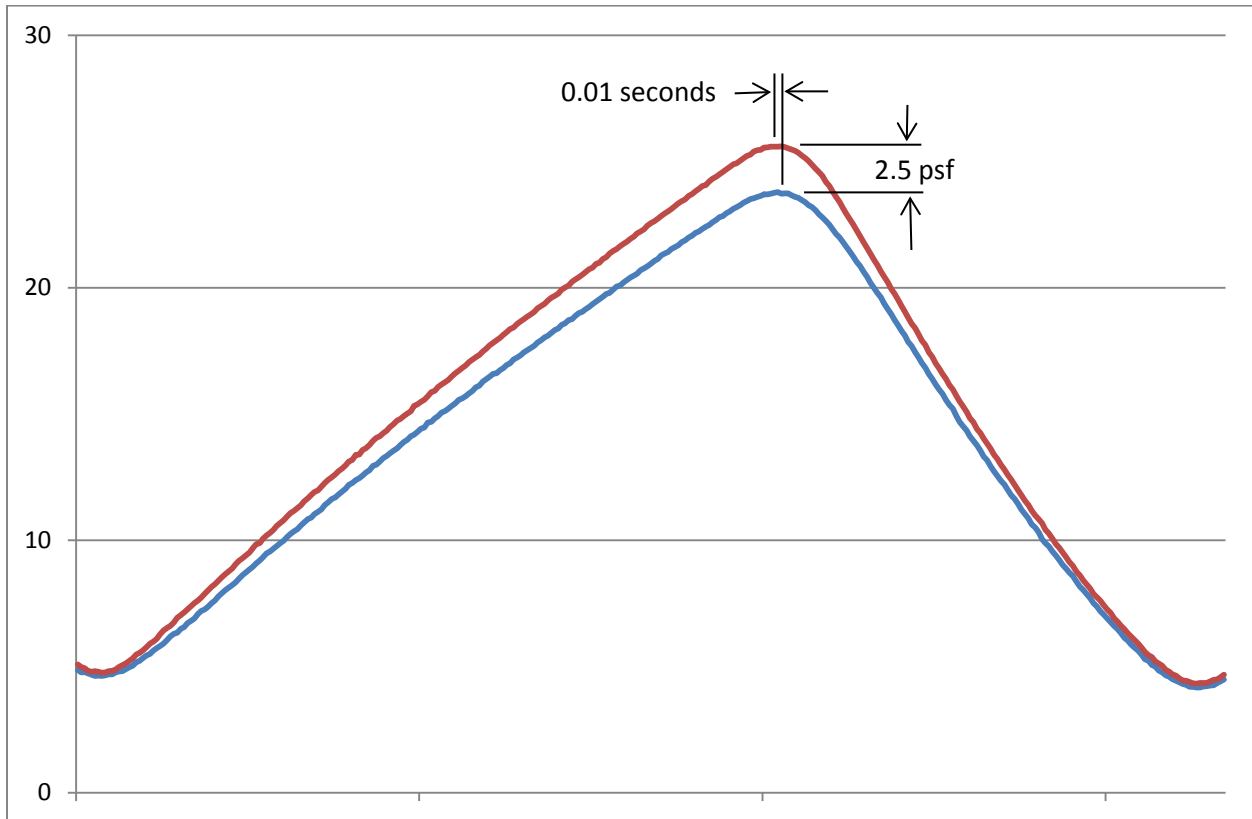

Appendix B

Photographs



Exterior face of test specimen



Interior face of test specimen

Appendix C

Drawings



Report #: E5985-901-44

Date: 03/31/15

Verified by: *[Signature]*

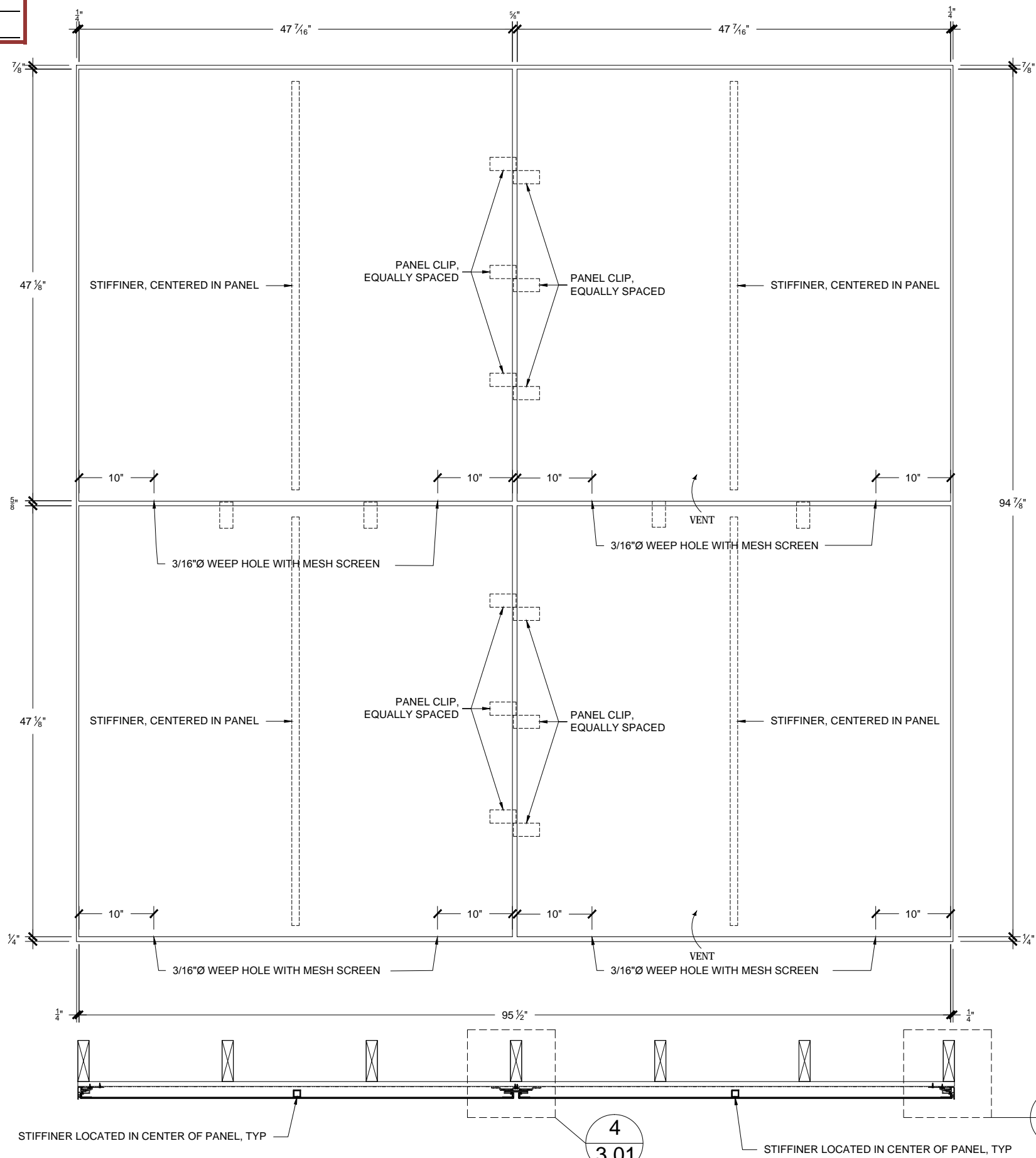

1
3.01

2
3.01

3
3.01

4
3.01

5
3.02

SECTION A-A

SECTION B-B

GENERAL NOTES:

FIRM NAME & ADDRESS:



"RISE SYSTEM"

204 Hawley Street
Lynden, WA 98264
p. 360-354-3155
shane@phoenix-mw.net

THE INFORMATION CONTAINED ON THIS DRAWING IS PROPRIETARY AND WILL NOT BE COPIED OR DISCLOSED TO OTHERS WITHOUT THE EXPRESS WRITTEN PERMISSION OF PHOENIX PANEL SYSTEM © 2013

PROJECT:
PHOENIX PANEL SYSTEM
TYPICAL DETAILS

DATE:
3/5/15

SCALE:

REVISION:
A

SHEET:

DRAWN BY:
B.ZIMA

3.01

Report #: E5985-901-44
 Date: 03/31/15
 Architectural Testing Verified by: *[Signature]*

GENERAL NOTES:

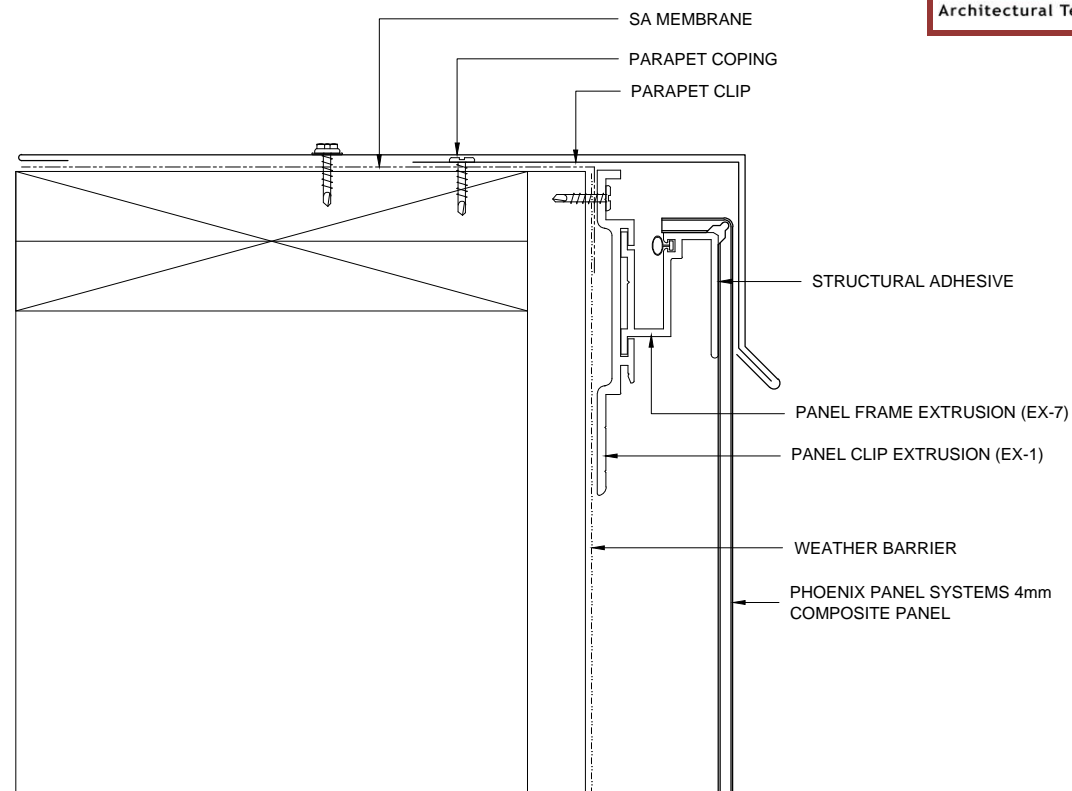

1 PARAPET COPING DETAIL

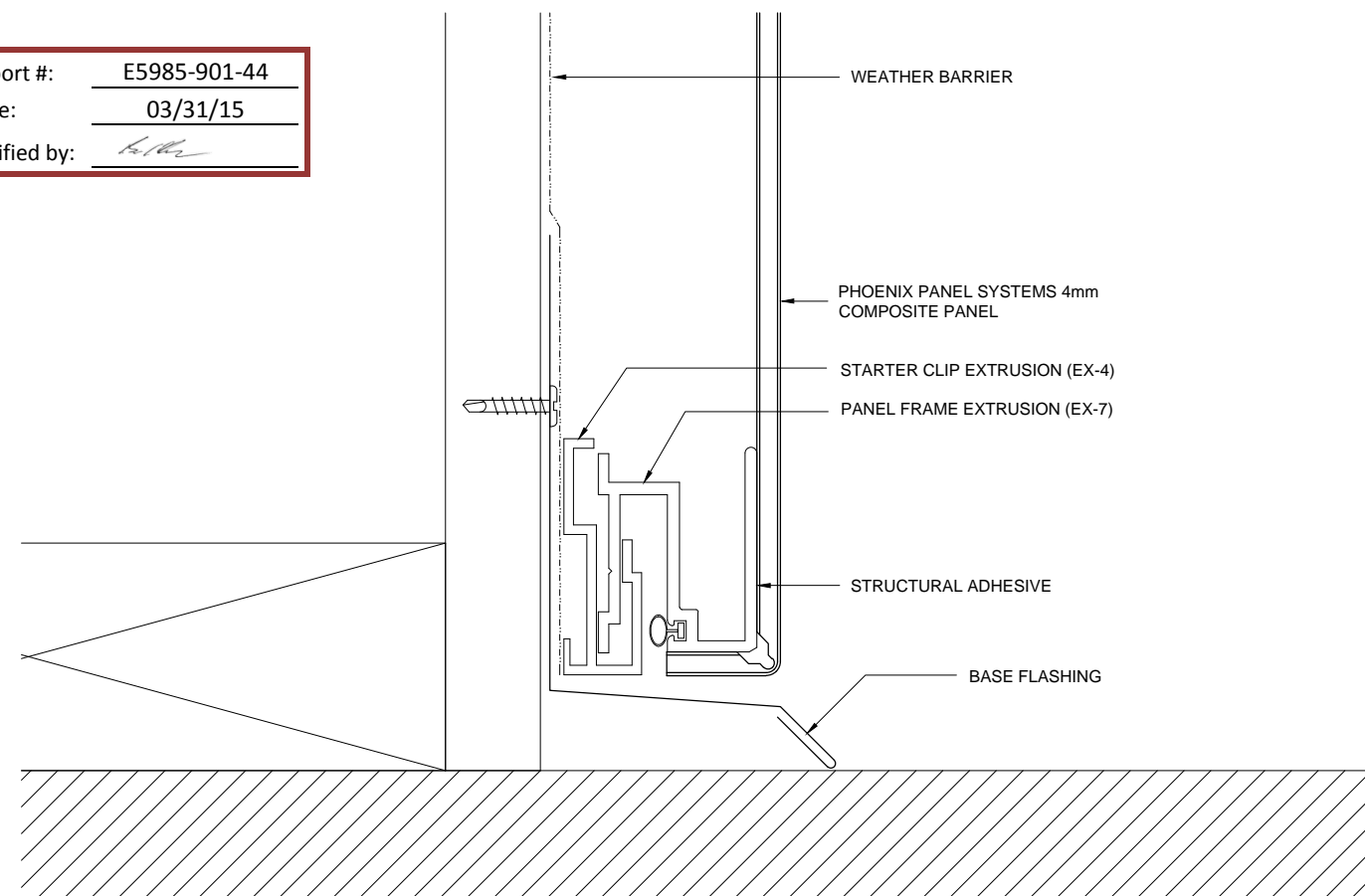

3 BASE DETAIL

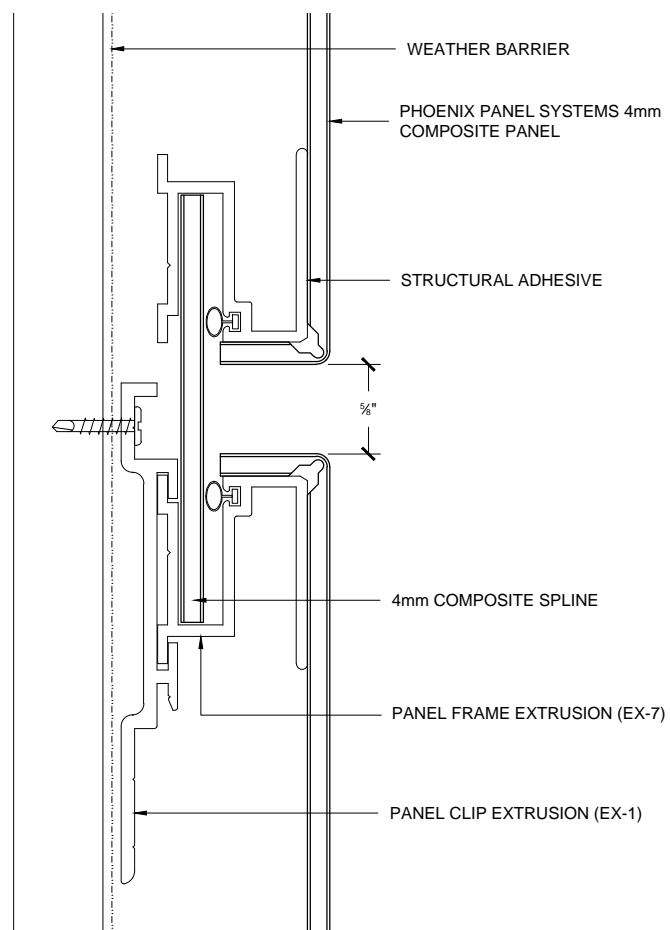

2 HORIZONTAL JOINT DETAIL

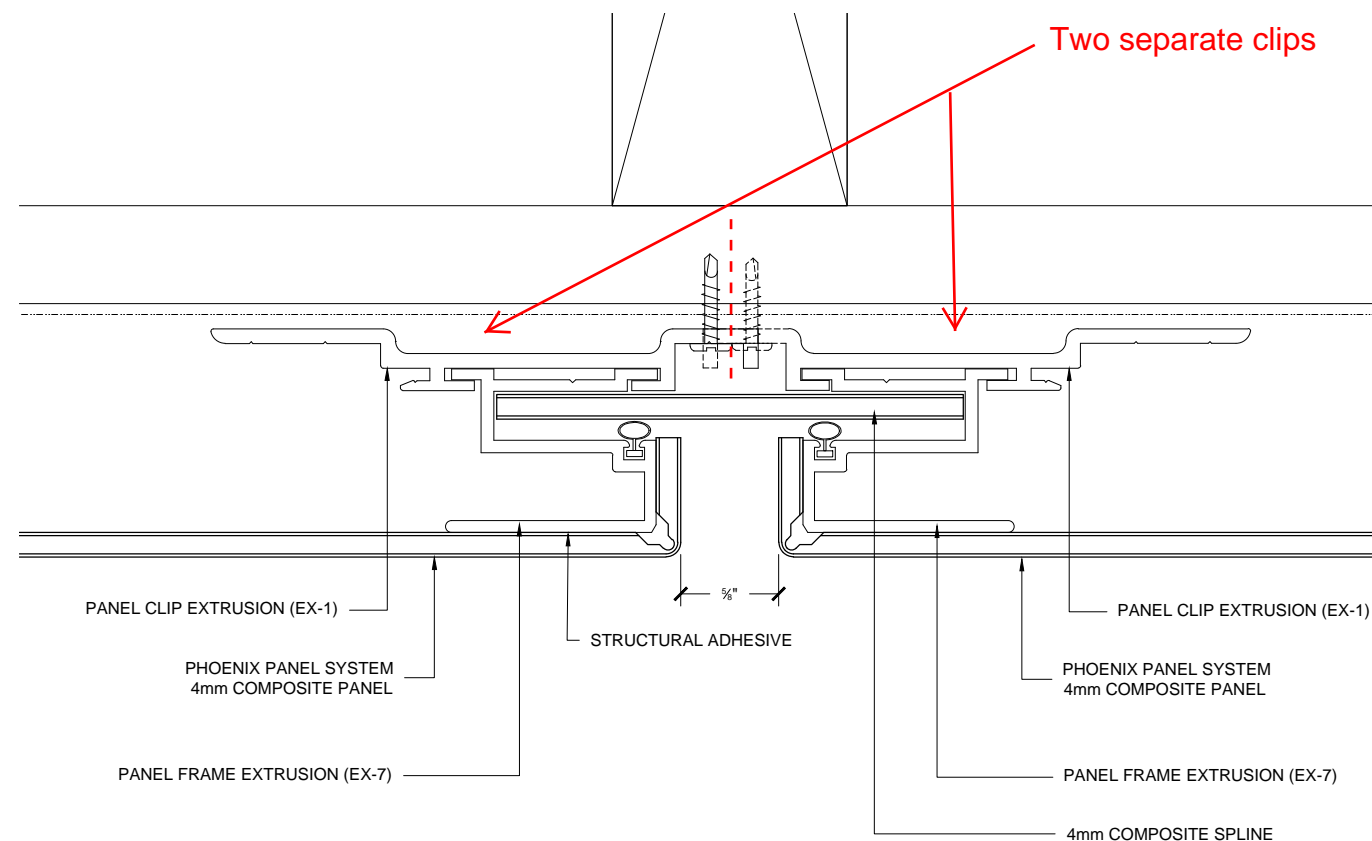

4 VERTICAL JOINT DETAIL

FIRM NAME & ADDRESS:



"RISE SYSTEM"

204 Hawley Street
 Lynden, WA 98264
 p. 360-354-3155
 shane@phoenix-mw.net

THE INFORMATION CONTAINED ON THIS DRAWING IS PROPRIETARY AND WILL NOT BE COPIED OR DISCLOSED TO OTHERS WITHOUT THE EXPRESS WRITTEN PERMISSION OF PHOENIX PANEL SYSTEM © 2013

PROJECT:
**PHOENIX PANEL SYSTEM
 TYPICAL DETAILS**

DATE:
3/5/15

SCALE:

REVISION:
A

SHEET:

DRAWN BY:
B. ZIMA

3.01

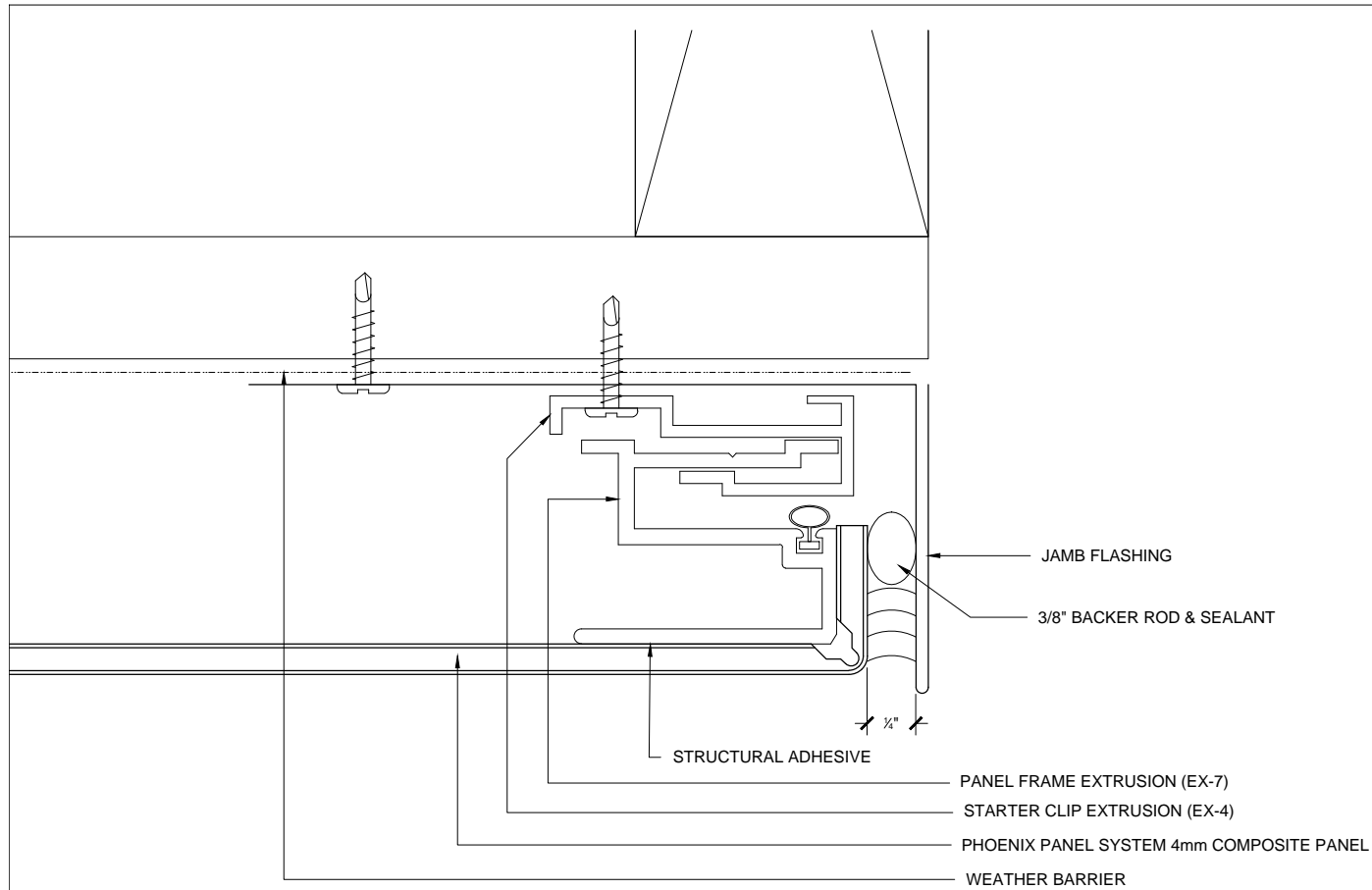

5 JAMB DETAIL

 Report #: E5985-901-44
 Date: 03/31/15
 Architectural Testing Verified by: *[Signature]*

GENERAL NOTES:

FIRM NAME & ADDRESS:



PHOENIX
 "RISE SYSTEM"
 204 Hawley Street
 Lynden, WA 98264
 p. 360-354-3155
 shane@phoenix-mw.net

THE INFORMATION CONTAINED ON THIS DRAWING IS
 PROPRIETARY AND WILL NOT BE COPIED OR DISCLOSED
 TO OTHERS WITHOUT THE EXPRESS WRITTEN
 PERMISSION OF PHOENIX PANEL SYSTEM © 2013

PROJECT:
**PHOENIX PANEL SYSTEM
 TYPICAL DETAILS**

DATE: 3/5/15	SCALE:
REVISION: A	SHEET:
DRAWN BY: B. ZIMA	3.02